

**Byers Gill Solar  
EN010139**

# 7.2 Design Approach Document

Planning Act 2008

APFP Regulation 5(2)(q)

Infrastructure Planning (Applications: Prescribed Forms  
and Procedure) Regulations 2009

Volume 7

Deadline 5 - March November 2024

Revision 3 ~~2~~



<b>Table of Contents</b>		<b>Page</b>
<b>1.</b>	<b>Introduction</b>	<b>1</b>
1.1.	Purpose of this document	1
1.2.	Structure of this document	1
1.3.	Development of this document	2
<b>2.</b>	<b>The Proposed Development</b>	<b>4</b>
2.1.	Project Description	4
<b>3.</b>	<b>Our vision</b>	<b>6</b>
<b>4.</b>	<b>Design context</b>	<b>7</b>
4.1.	Introduction	7
4.2.	Overarching NPS for Energy (EN-1)	7
4.3.	NPS for Renewable Energy Infrastructure (EN-3) and NPS for Electricity Networks Infrastructure (EN-5)	8
4.4.	Local policies on good design	9
4.5.	The NIC's Four Principles of Good Design	9
4.6.	The Mitigation Hierarchy	10
4.7.	Applying 'good design'	10
<b>5.</b>	<b>Location context</b>	<b>12</b>
5.2.	Landscape and Visual	14
5.3.	Cultural Heritage	15
5.4.	Biodiversity	15
5.5.	Land Use	16
<b>6.</b>	<b>Design evolution</b>	<b>19</b>
6.1.	Overarching design objectives	19
6.2.	Design iteration	19
<b>7.</b>	<b>The Design Response</b>	<b>22</b>
7.2.	Technical infrastructure	22
7.3.	Landscape and environmental design	35
7.4.	Outcomes of the design response	39
7.5.	Summary	42
<b>8.</b>	<b>The Design Parameters</b>	<b>43</b>
8.1.	Introduction and definitions	43
8.2.	Design Approval	44
8.3.	Design parameters	44
8.4.	Technology Advancements	55
<b>9.</b>	<b>Conclusion</b>	<b>58</b>

## Table of Plates

Plate 2-1 Landscape Concept Masterplan (Document Reference 6.2.3.20)	5
--	---

Plate 5-1 Location Plan (Document Reference 6.3.1.1)	13
Plate 5-2 Indicative cross section showing proposed orchard area	18
Plate 6-1 Design evolution timeline	21
Plate 7-1 Indicative cross sections showing woodland mosaic	23
Plate 7-2 Typical transformer, inverter and BESS arrangement (Document Reference 6.2.3.10)	26
Plate 7-3 Typical Access and Supporting Infrastructure Layout (Document Reference 6.3.2.11)	28
Plate 7-4 Typical fence and gate (Document Reference 6.3.2.15)	31
Plate 7-5 Indicative cross section showing public rights of way	34
Plate 7-6 Indicative cross section showing picnic area	38

## **Table of Tables**

Table 1-1 Engagement during the drafting of the Design Approach Document	2
Table 5-1 Agricultural land and soil resource sensitivities	17
Table 7-1 Residual significant landscape and visual effects	40
Table 8-1 Design parameters	44

# 1. Introduction

## 1.1. Purpose of this document

- 1.1.1. This Design Approach Document (DAD) has been prepared to support the Development Consent Order (DCO) Application for Byers Gill Solar (the Proposed Development) and will become a certified document through the DCO should it be granted consent.
- 1.1.2. By becoming a certified document through the powers of the DCO, it places a duty on the Applicant (RWE), the future contractor and the relevant stakeholders to ensure that the detailed design and associated infrastructure is delivered in accordance with the parameters and principles outlined within Chapter 8, and subsequently secured by this document.
- 1.1.3. The parameters and principles as provided within Table 8-1 would be secured by requirement 3 of the DCO. The Proposed Development will also be controlled by other certified documents submitted in support of the DCO Application – see the Application Document Tracker (Document Reference 1.5) for further information.
- 1.1.4. Through the Proposed Development’s design evolution, the Applicant has adhered to rigorous technical, functional and safety-led design requirements. The Applicant has also sought to ensure that local communities can continue to enjoy the surrounding landscape and natural environment. As a result, the design has taken into account the existing environment and how local communities and visitors to the area interact with the local landscape. The remaining Chapters of this document seek to provide a summary of the landscape and environmental context of the area in which the Proposed Development is sited, and subsequently provide a detailed account of how the design of the Proposed Development has sought to respond to this context, and present a design which is in keeping with the local area.

### **Interaction with other application documents**

- 1.1.5. The Applicant has prepared this document with the intended purpose of it to be read alongside and supplement other application documents, namely the Outline Landscape and Ecology Management Plan (LEMP) (Document Reference 6.4.2.14), ES Chapter 7 Landscape and Visual (Document Reference 6.2.7), the Consultation Report (Document Reference 5.1) and the Mitigation Route Map (Document Reference 7.8).

## 1.2. Structure of this document

- 1.2.1. This Document is organised into chapters, in so far as is possible in a logical and chronological order, detailing the consideration to policy, the existing context and the necessary safety requirements when designing a solar farm.



- 1.2.2. A short summary of what can be found in each chapter is provided below:
- **Chapter 1 Introduction** – provides an introduction to the Document and the interaction of this document with the wider application.
  - **Chapter 2 The Proposed Development** – provides a summary of the description of the Proposed Development.
  - **Chapter 3 Our vision** – outlines the vision that the Applicant has developed in collaboration with stakeholders.
  - **Chapter 4 Design context** – summarises the relevant national and local policy requirements for achieving ‘good design’.
  - **Chapter 5 Location context** – provides a summarised description of the existing landscape, referring to landscape and visual, cultural heritage and archaeology, biodiversity and land use.
  - **Chapter 6 Design evolution** – provides an account of how the design of the Proposed Development has evolved since conceptualisation until DCO submission.
  - **Chapter 7 The Design Response** – provides an account of how the design of the Proposed Development has responded to the design context and the location context, detailing the remaining landscape and visual effects.
  - **Chapter 8 The Design Parameters** – seeks to secure the design parameters and principles for the Proposed Development, and should be read in conjunction with the draft DCO (Document Reference 3.1).
  - **Chapter 9 Conclusion** – sets out the conclusions of this Document, and how the Applicant has sought to design the Proposed Development in a sympathetic way.

### 1.3. Development of this document

- 1.3.1. The development of the design of the Proposed Development has included extensive engagement with local landowners, business owners, residents and statutory stakeholders and regulators. For a detailed account of the engagement and consultation undertaken during the pre-application period, please see the Consultation Report (Document Reference 5.1).
- 1.3.2. Additionally, this Design Approach Document has been developed through ongoing engagement with key stakeholders. A summary of this engagement is provided in Table 1-1.

**Table 1-1 Engagement during the drafting of the Design Approach Document**

Issue status and date	Stakeholder	Summary of comments
23 August 2023	Darlington Borough Council	N/A – no comments received to date.
Proposed structure and essay plan of content to be included within the Document	Durham County Council	20 September 2023 Confirmed that they had no comments to make on the proposed structure.

Issue status and date	Stakeholder	Summary of comments
	Stockton-on-Tees Borough Council	31 August 2023 Confirmed that they had no comments to make on the proposed structure.
	Historic England	9 September 2023 Satisfied that cultural heritage was given consideration as part of the proposed structure and suggested that dependent on the level of detail provided in a full draft, sub-sections per type of asset may be required.
	Natural England	N/A – no comments received to date.
	Environment Agency	6 September 2023 Confirmed that they had no comments to make on the proposed structure, and do not wish to review further iterations of the Document.
24 August 2023 Proposed structure and essay plan of content to be included within the Document.	The Planning Inspectorate	18 September 2023 Confirmed that they had no comments to make on the proposed structure.
11 January 2024 Initial draft of the Document.	The Planning Inspectorate	2 February 2024 Provided feedback on the structure of the draft document, and suggested ways in which sense of place and evidence of consideration of policy can be highlighted.

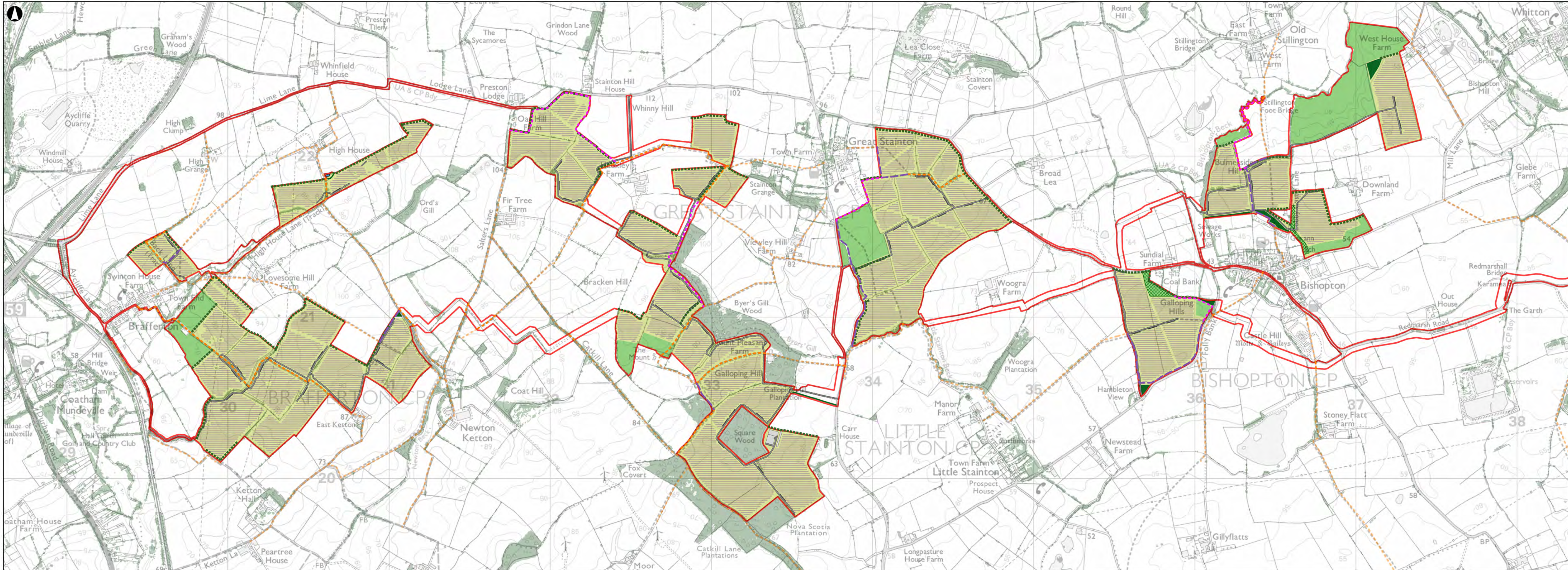
## 2. The Proposed Development

### 2.1. Project Description

- 2.1.1. The Proposed Development consists of a solar farm capable of generating over 50MW Alternating Current (AC) of electricity with co-located BESS, located between Darlington and Stockton-on-Tees in north-east England. The Proposed Development is approximately 490ha and comprises six Panel Areas (groups of solar photovoltaic (PV) panels) (Panel Areas A-F). The solar PV panels would be mounted on a metal frame in groups, fixed in position with panels facing south. An on-site substation would be located within Panel Area C.
- 2.1.2. The Proposed Development includes up to 32.5km of 33kilovolt (kV) underground cabling between the Panel Areas and the on-site substation, as well as approximately 10km of 132kV underground cable to connect the Proposed Development to the grid connection at the existing Norton substation (located to the north-west of Stockton-on-Tees). This cabling could be placed either within roads or through off-road options. A range of supporting infrastructure is required for the Proposed Development, comprising: BESS; transformers and inverters; storage containers to hold this equipment; and security measures such as fencing, CCTV and lighting.
- 2.1.3. The Proposed Development includes environmental mitigation and enhancement measures to avoid or reduce adverse impacts on the surrounding environment and nearby communities, as shown on Plate 2-1 overleaf.
- 2.1.4. For a full Description of Development, please refer to ES Chapter 2 The Proposed Development (Document Reference 6.2.2).

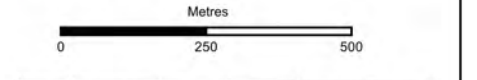
**Plate 2-1 Landscape Concept Masterplan (Document Reference 6.2.3.20)**





- Legend**
- - - Existing Public Right of Way
  - Existing Vegetation and Woodland
  - Concept Masterplan Proposals**
  - PV Areas
  - Onsite Substation
  - Internal Access
  - Battery Energy Storage System
  - Biodiversity Enhancement / Wildflower Meadow
  - Tree Planting
  - Amenity Recreation Areas
  - Proposed Mitigation Hedgerow with Trees
  - Planting and Seeding Areas
  - Proposed Access Amendments**
  - Proposed Permissive Route
  - Proposed Re-route

Coordinate System: British National Grid  
 © Crown copyright. All rights reserved. 2022 License number 100020565 | Contains Ordnance Survey data © Crown copyright and database right 2022



PO3	25/01/24	JM	DL	DL	DL
Rev	Date	By	Chkd	Appd	Authd



Client  
**Byers Gill Solar**

Drawing Title  
**ES Figure 2.20  
 Landscape Concept Masterplan**

Scale at A3  
**1:13000**

Role  
**Final**

Subtable  
**Development Consent Order (DCO)**

Project Number <b>286386-00</b>	Rev <b>P02</b>
Drawing Number <b>BGS-ES02-00012</b>	

**Figure 2.20**



### 3. Our vision

- 3.1.1. Identified by the UK Government as a critical national priority, the renewable energy produced by Byers Gill Solar will be enough to power up to 70,000 homes and displace over 4 million tonnes of CO<sub>2</sub> from equivalent fossil fuel energy.
- 3.1.2. Located in North East of England, the Proposed Development sits predominantly in the Borough of Darlington which is abundant in cultural heritage and rich in ecological diversity. In recognition of selected location for the Proposed Development, the Applicant has sought to design Byers Gill Solar in a way which aims to enhance the local features, whilst still proposing a safe and productive form of solar energy generation.
- 3.1.3. In addition to the solar panel areas, the Battery Energy Storage Systems (BESS), an on-site substation, underground cabling and other supporting infrastructure, the Proposed Development will host a series of wider mitigation and enhancement measures, putting the local landscape, ecology environmental and communities at the heart of the design.
- 3.1.4. In addition to generating enough renewable power for up to 70,000 homes, the Proposed Development would provide a series of wider benefits, both locally and nationally, such as:
- the displacement of over 4m tonnes of CO<sub>2</sub> from equivalent fossil fuel energy, which equates to taking approximately 101,000 cars off the road for a year;
  - ~~approximately 7km of~~ new and enhanced hedgerows, ~~59 hectares of~~ planting and seeding between panel areas, ~~24 hectares of~~ community picnic areas and orchards, ~~3 hectares of~~ new trees and ~~29 hectares of~~ biodiversity enhancement areas;
  - allocating two large fields in the Order Limits solely for habitat enhancement, which will be sown without fertiliser to help lower nutrients in the soil, and will be retained during the 40-year duration of the Proposed Development specifically for ground nesting birds;
  - providing an anticipated 87% net gain of in area habitat Biodiversity Units (BUs) and a 108% net gain of hedgerow BUs;
  - providing approximately 3600m of permissive paths to be implemented during the construction stage, enhancing the local public right of way network;
  - interpretation boards to be provided at points of local interest along the public right of way network;
  - the provision of a community orchard in Bishopton;
  - the provision of a sensory garden and car park for the Bishopton Redmarshall Primary School; and
  - £27m generated in business rates over the lifetime of the Proposed Development, alongside approximately 200 jobs during construction.
- 3.1.5. As evidenced in the remaining chapters of this document, Byers Gill Solar has been designed in such a way that it will celebrate and enhance the historical, ecological and landscape features of the surrounding communities, and which will enable renewable energy generation for the next 40 years, should it be granted development consent.

## 4. Design context

### 4.1. Introduction

- 4.1.1. This chapter (Chapter 4) provides a summary of the planning policy documents and guidance considered to be relevant and important to the good design of the Proposed Development.
- 4.1.2. It provides an overview of the design requirements established by the relevant National Policy Statements (NPS), and the National Infrastructure Commission's (NICs) Principles of Good Design.

### 4.2. Overarching NPS for Energy (EN-1)<sup>1</sup>

- 4.2.1. The Proposed Development has been designed in accordance with NPS EN-1 and the requirements set out regarding good design. NPS EN-1 was designated in January 2024, as an update to the previous suite of energy NPSs designated in 2011.
- 4.2.2. NPS EN-1 introduces the critical national priority (CNP) for low carbon infrastructure. Set out in section 4.2 of NPS EN-1, the CNP explicitly identifies the need for nationally significant low carbon infrastructure in order to meet Government decarbonisation targets and achieve net zero ambitions. Paragraph 4.2.5 confirms that solar photovoltaic generation is a form of CNP infrastructure.
- 4.2.3. Paragraph 4.2.6 states that substantial weight should be given to the overarching need case for CNP infrastructure, as a starting point for determination of energy infrastructure applications. It is clarified in paragraphs 4.2.7 - 4.2.9 that this need case is to be considered taking into account the impacts of the project and the application of the mitigation hierarchy, however the CNP policy will influence how residual impacts are considered in the overall planning balance. Whilst further detail on this is provided in Chapter 5 of the Planning Statement (Document Reference 7.1) NPS EN-1 is referring here to the policy position that for CNP infrastructure, residual impacts remaining after application of the mitigation hierarchy are unlikely to outweigh the urgent need for its development. Exceptions to this relate to a limited, specified set of unacceptable risks presented by residual impacts.
- 4.2.4. Section 4.7 of NPS EN-1 establishes the need for "good design" in energy infrastructure, identifying in paragraphs 4.7.1-4 that implementing good design can:
- Create high quality, inclusive design which is also fit for purpose and sustainable;
  - Create sustainable infrastructure which is sensitive to place;
  - Be a means through which many NPS policy objectives can be met; and
  - Mitigate adverse effects of a project.

---

<sup>1</sup> [Overarching National Policy Statement for energy \(EN-1\) - GOV.UK \(www.gov.uk\)](https://www.gov.uk/government/policies/overarching-national-policy-statement-for-energy-en-1)

- 4.2.5. At 4.1.7, NPS EN-1 defines the ‘mitigation hierarchy’ as measures to “*avoid, reduce, mitigate or compensate for any adverse impacts*”, and clarifies at 4.3.8 that references to ‘impacts’ within the NPS should be taken to mean ‘likely significant impacts’. Section 4.2.11 indicates that the mitigation hierarchy must be applied to projects and that residual impacts should only be those which “*cannot be avoided, reduced or mitigated*”.
- 4.2.6. Applicants are encouraged to embed good design within a project from the outset, with paragraph 4.7.5 referring to the use of “design principles” to be established to guide the project from conception to operation. Paragraph 4.7.7 requires that applicants demonstrate in their DCO application how the design process was conducted and evolved, and why a favoured choice was selected where different designs were considered.
- 4.2.7. Paragraphs 4.7.6 and 4.7.10-12 of NPS EN-1 recognise the role of functionality and operational requirements in designing new energy infrastructure, in which the scope of the design approach may be constrained or limited in some respects due to the need for a functional, safe and secure development. However, the benefits of ensuring both functionality and aesthetics are highlighted with regard to ensuring a proposal is sensitive to its location, contributes to the quality of an area where possible and remains durable and adaptable.

### **4.3. NPS for Renewable Energy Infrastructure (EN-3)<sup>2</sup> and NPS for Electricity Networks Infrastructure (EN-5)<sup>3</sup>**

- 4.3.1. NPS EN-3 and NPS EN-5 set out technology-specific policy, relating to solar infrastructure and electricity networks infrastructure respectively. They make reference to the overarching principles of good design as set out in NPS EN-1, with the concept underpinning the approach outlined in many policy topics across the NPS suite.
- 4.3.2. NPS EN-3 identifies in section 2.3 that a number of factors may influence site selection and design, recognising that most renewable energy resources can only be developed where that resource exists and is economically feasible. Paragraphs 2.10.19-26 identifies how irradiance, topography and grid connection are key factors for solar farm siting and commercial viability, noting the need to consider cumulative effects where there may be other energy generating stations in proximity.
- 4.3.3. NPS EN-5 paragraph 2.2.7 note that it is not necessarily always the case that the cable route should be the most direct, as there will be other factors including engineering and environmental aspects. Paragraph 2.2.1-6 states that siting is not always within the control of the applicant and is determined by the location of new generating stations and system capacity, but that applicants do have control over the routing and site

---

<sup>2</sup> [National Policy Statement for renewable energy infrastructure \(EN-3\) - GOV.UK \(www.gov.uk\)](https://www.gov.uk/government/policies/national-policy-statement-for-renewable-energy-infrastructure)

<sup>3</sup> [National Policy Statement for electricity networks infrastructure \(EN-5\) - GOV.UK \(www.gov.uk\)](https://www.gov.uk/government/policies/national-policy-statement-for-electricity-networks-infrastructure)



selection. Locational constraints do not exempt candidates from balancing site-selection or good design considerations. Paragraphs 2.2.8-9 of NPS EN-5 state that the flexibility of locating substations should allow the applicant to consider local characteristics and screening and other mitigation options.

#### **4.4. Local policies on good design**

4.4.1. As detailed in Table 5-1 of the Policy Compliance Document (Document Reference 7.1.1), the Darlington Local Plan policies DC1 and ENV1, which are strategic policies of the plan, make reference to the need for good design in new development. DC1 sets out that this is required to create attractive and desirable places, as well as reduce carbon emissions and increase resilience of development to the effects of climate change. ENV1 refers to the ability of good design to reduce or avoid effects on heritage assets and their settings.

#### **4.5. The NIC's Four Principles of Good Design<sup>4</sup>**

- 4.5.1. The NIC published Design Principles for National Infrastructure in 2020, developing four principles to guide the planning and delivery of major projects. The four principles are: climate, people, places, and value. When enacting these principles, the wider context should be appreciated, engagement should be meaningful, and there should be continuous measurement and improvement.
- 4.5.2. The 'climate' principle refers to mitigating greenhouse gas emissions and adapting to climate change. Opportunities to do this may be beyond the site boundary of a project and should be sought during design and construction to enable decarbonisation and the mitigation and offsetting of residual emissions. Good design should also incorporate flexibility so that projects are adaptable and resilient to climate change.
- 4.5.3. Infrastructure should reflect what society wants and share benefits widely (the 'people' principle). This refers to designing to a human scale, being easy to navigate and improve the quality of life of those who interact with it. Spaces should be accessible, enjoyable and safe, and improve health and wellbeing. Community views should be taken into account and reflected in design, although it won't be possible to please everyone.
- 4.5.4. Infrastructure should give 'places' a sense of identity and improve our environment. Projects should make a positive contribution to local landscapes and ecology, and respect and enhance local culture and character. Opportunities to benefit the built and natural environment beyond the site boundary should be sought.
- 4.5.5. To provide 'value', infrastructure projects should achieve multiple benefits and solve problems well. Opportunities to secure economic, environmental and social benefits should be identified and pursued, as well as solving multiple problems with one solution and seeking to add value beyond the site boundary and purpose of the infrastructure.

---

<sup>4</sup> [NIC-Design-Principles.pdf](#)

## 4.6. The Mitigation Hierarchy

- 4.6.1. The design process has incorporated a practical hierarchy of mitigation with the purpose of identifying how potential impacts can be avoided or reduced if at all possible. The first option would be to avoid the impacts at source, which would involve removing the feature or re-siting it to an area where it would have no or reduced effects. In some instances, it is not possible to avoid impacts altogether and the potential to reduce impacts has been explored.
- 4.6.2. It is acknowledged that not all impacts will be able to be avoided, and in some cases even reduced. The proposals have therefore also considered mitigation to offset adverse effects on the environment, such as providing additional community benefits to compensate for the potential loss of access or visual amenity.
- 4.6.3. Mitigation measures proposed to prevent, reduce or offset likely adverse effects have been identified and developed as part of the iterative design process. The primary mitigation measures have been embedded into the project design and are referred to as embedded mitigation. Where avoidance of an impact through embedded mitigation is not possible, or is only partly effective, further 'essential mitigation' is considered. Further definition of mitigation measures is provided in Section 4.5 in ES Chapter 4 Approach to EIA (Document Reference 6.2.4).

## 4.7. Applying 'good design'

- 4.7.1. An appraisal of how the Proposed Development is in compliance with relevant planning policy relating to good design is provided in the Planning Statement (Document Reference 7.1) and its Appendix A Policy Compliance Document (Document Reference 7.1.1).
- 4.7.2. The remainder of this document demonstrates how the Proposed Development has taken into account the criteria of the NPS in relation to good design. It sets out the local context in which the Proposed Development is situated and outlines the design response to that context in seeking to mitigate adverse impacts and integrate good design principles. Recognising the constraints presented by some infrastructure, it also identifies how technical considerations have in some instances limited design choices.
- 4.7.3. This document is complemented by the account of alternatives considered in developing the design which is provided in ES Chapter 3 Alternatives and Design Iteration (Document Reference 6.2.3). That chapter demonstrates that good design principles have been incorporated into the approach to the Proposed Development since inception, with early site selection seeking to balance operational and functional needs with the intention to avoid, where possible, sensitive environments and constraints. The iterative approach to design has sought to ensure that changes could be made in response to assessment and feedback to better fit the proposals into the existing context, avoid or reduce adverse effects and deliver enhancement where feasible.

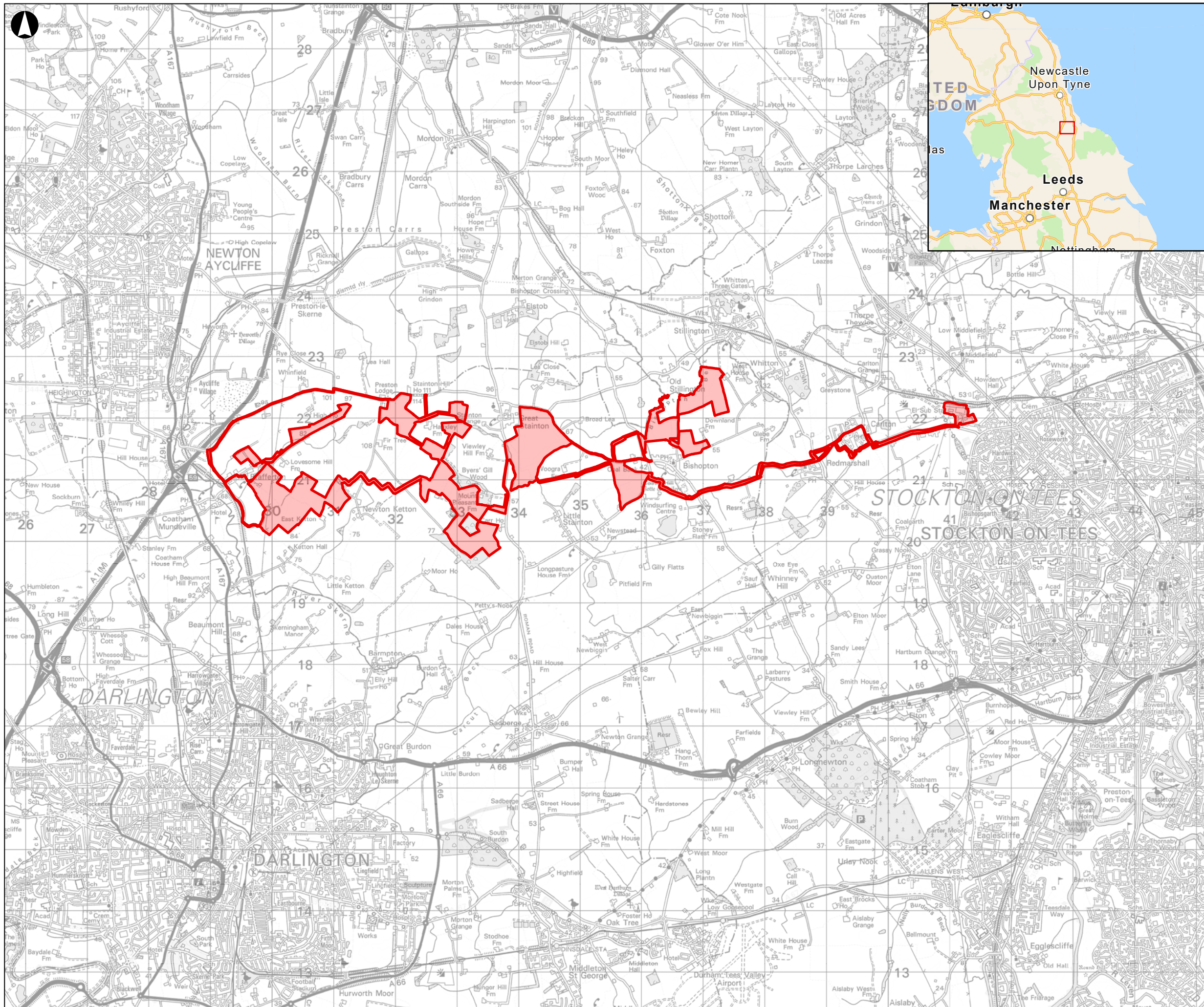
- 4.7.4. As set out in Section 4.6 of this document, throughout the design process, changes have been made and implemented into the design of the Proposed Development to avoid or reduce adverse environmental effects and to make the Proposed Development fit better into the wider landscape. To secure the delivery of good design, should development consent be granted, section 8 of this DAD includes a list of design principles which underpin the Proposed Development and which would be required to be retained in the future detailed design as secured via requirement 3 of the DCO (Document Reference 3.1).
- 4.7.5. Taking into account the points summarised above, it is concluded in the Planning Statement (Document Reference 7.1) that the Proposed Development is in compliance with policy relating to good design. Please refer to that document and its Appendix A Policy Compliance Document (Document Reference 7.1.1) for further detail on the policy appraisal.

## 5. Location context

- 5.1.1. The majority of the Proposed Development, including the panel areas, substation and on-site BESS are located within the administrative area of Darlington Borough Council. The eastern part of the cable routes crosses into the administrative area of Stockton-on-Tees Borough Council. The northern extent of the planning boundary (the 'Order Limits') borders Durham County Council's administrative area. The location of the Proposed Development is shown on Plate 5-1 overleaf.
- 5.1.2. The Order Limits and surroundings comprise of agricultural fields, interspersed with individual trees, hedgerows, farm access tracks, woodlands and local farm holdings. There are several local villages located within close proximity to the Proposed Development, including Brafferton, Newton Ketton, Great Stainton, Bishopton and Old Stillington. For a detailed account of the site selection process, and why therefore the location of the Proposed Development was decided upon, please see ES Chapter 3 Alternatives and Design Iteration (Document Reference 6.2.3).

**Plate 5-1 Location Plan (Document Reference 6.3.1.1)**



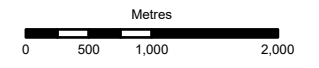


Legend  
 Order Limits

A3

8/22/2024 4:10 PM

Coordinate System: British National Grid  
 This map is reproduced from Ordnance Survey material with the permission of Ordnance Survey on behalf of the controller of Her Majesty's Stationery Office. © Crown Copyright. Unauthorised reproduction infringes Crown copyright and may lead to prosecution or civil proceedings. LICENCE NUMBER: 0100031673 [2022]  
 Esri UK, Esri, TomTom, Garmin, FAO, NOAA, USGS



P04	22/08/2024	JEP	LM	TS	DB
Rev	Date	By	Chkd	Appd	Authd

Client



Project Name  
**Byers Gill Solar**

Drawing Title  
**Figure 1.1  
 Location Plan**

Scale at A3	1:60,000
Role	Issue
Suitability	<b>Environmental Statement</b>
Project Number	286386-00
Drawing Number	BGS-ES01-00001
Rev	<b>P04</b>



## 5.2. Landscape and Visual

- 5.2.1. The Order Limits are in an agricultural area, with woodland, hedgerows and hedgerow trees filling the surrounding environment, leading to largely constrained views across the landscape.
- 5.2.2. As this document goes on to explore, the design of the Proposed Development has considered the existing landscape and nature of the surrounding communities, and has been developed in a way which will see enhancements made to the landscape.
- 5.2.3. The Proposed Development will be surrounded by land featuring undulating mixed farmland, abundant with nature, including woodland, hedgerows and hedgerow trees – as well as other solar farms - which mark out the different fields. The land is also delineated by fences, ditches and watercourses.
- 5.2.4. However, Byers Gill Solar is not located in any national or local landscape designations. The nearest national landscape designations are Registered Parks and Gardens located approximately 5km from the proposed Panel Areas. The nearest Area of Outstanding Natural Beauty (AONB) and National Parks are more than 20km away.
- 5.2.5. There are two Areas of High Landscape Value (AHLV) within 2km of the Proposed Development. The Elstob AHLV is located approximately 30m north of the Panel Area B, and the Bradbury, Preston and Mordon Carrs AHLV is located approximately 1.1km north of Panel Area A. Additionally, the Proposed Development is located within two local landscape character areas. Panel Areas A-D are within 6: Great Stainton Farmland and Panel Areas E and F are within 7: Bishopton Vale.
- 5.2.6. Woodland, hedgerows and hedgerow trees are relatively frequent in this area and along with the undulating landform serve to constrain visibility, though there are some more elevated and open locations with wider views. The lower lying and flatter area to the east has more arable farming and is less vegetated, leading to more open views.
- 5.2.7. The potential cable route options connecting the on-site substation with the Norton Substation pass through character areas within the Stockton-on-Tees Borough Council Area: 1 West Stockton Rural Fringe and 3 Billingham and Thorpe Becks.
- 5.2.8. The three relevant Local Planning Authorities (LPAs) provide baseline descriptions of the landscape character areas. These have been used to inform consideration of the sensitivity of the landscape character areas, and include:
- Darlington LCA Landscape Character Areas;
  - Stockton on Tees LCA Landscape Character Areas;
  - Stockton on Tees Landscape Capacity Study (2011);
  - County Durham Local Landscape Designation Review (2019);
  - County Durham Landscape Value assessment (2019); and
  - County Durham Local Landscape Designation Review (2019).

- 5.2.9. For more information, please refer to ES Chapter 7 Landscape and Visual (Document Reference 6.2.7).

### **5.3. Cultural Heritage**

- 5.3.1. Local history is best exemplified through the sites of archaeological importance and interest located in close proximity to, or within, the Order Limits.
- 5.3.2. To the south of Bishopton lies a motte and bailey castle, constructed in the 12<sup>th</sup> century, which is now a scheduled monument. Bishopton also contains a number of listed buildings and is a Conservation Area, reflecting its historic character. In more recent history, the fields south of Bishopton in Panel Area E were home to a First World War airfield. This was likely a sparse operation, and no remains can currently be found of this.
- 5.3.3. The earliest evidence of human activity in this area is from the Neolithic period, but there are few traces of human life in this area until the Iron Age. The area was occupied during the Saxon and Medieval periods, and local villages particularly grew during the 17<sup>th</sup> to 19<sup>th</sup> centuries, with the landscape being used for both agriculture and industrial production.
- 5.3.4. Geophysical surveys of the Order Limits were undertaken, which found some evidence of activity relating to the Bronze Age, the Romano-British period and medieval and post-medieval practices. Some of the activity includes agriculture and the remains of a roundhouse. Further intrusive trenching has been undertaken on a proportionate basis across some of the Order Limits and this has confirmed the initial results from the geophysical survey work as presented in ES Appendix 8.3 Detailed Gradiometer Survey Report (Document Reference 6.4.8.3).
- 5.3.5. For further information, see ES Chapter 8 Cultural Heritage and Archaeology (Document Reference 6.2.8).

### **5.4. Biodiversity**

- 5.4.1. The Proposed Development is situated in a rural area, with a wide range of ecology. The Order Limits are crisscrossed by hedgerows, and include grassland, woodland, scrub and watercourses. Following from the agricultural nature of landscape, most of the grassland has been agriculturally improved, but there remain some areas of less intensively managed grassland. The woodlands contain a variety of native trees, and the woodlands along watercourses are typically larger and mature, with some small areas of wet woodland and swamp vegetation.
- 5.4.2. Hedgerows mark the boundaries of fields and habitats, and are mostly made up of native species, although they do not provide a great deal of diversity. Similarly, the scrub, ponds and watercourse do not contain a variety of species and are of low ecological value. Plant-life found in the study area is common within the locality and is widespread.



- 5.4.3. Many of these ecological features provide a habitat for wildlife, mostly in the arable fields and grasslands, but also in the other ecological features that are spread through the Order Limits. Most of these habitats were found to be species-poor, lacked intrinsic botanical value, and were also widespread across the surrounding landscape. However, most of the hedgerows, ponds, areas of woodland and watercourses (particularly Byers' Gill and Bishopton Beck) qualify as local BAP priority habitats and/or habitats of principal importance.
- 5.4.4. There are also protected and priority species within the study area. Wintering and breeding birds enjoy the local habitats, in particular areas of open water, hedgerows, and open fields. The field margins, woodlands, grasslands, scrub and ponds found locally are all suitable habitats for invertebrates, amphibians and reptiles, but, with the exception of certain butterfly species, these are not considered to be of high ecological importance.
- 5.4.5. A number of different commuting and foraging bat species have been recorded within the study area, making use of habitats such as the hedgerows and woodland. There are also local badger setts, mostly along the field boundaries and in woodland. Although there are previous records of otters and water voles, there is a limited amount of suitable habitat available for them in the study area. Brown hares were seen in the study area, and the mosaic of arable fields, grassland and woodland edges make up the hare's preferred habitat. Although hedgehogs were not observed, scrub, hedgerows and grassland such as found in the Order Limits are suitable foraging habitats.
- 5.4.6. There are no designated sites within the Order Limits, although there are several in the nearby vicinity.

## 5.5. Land Use

- 5.5.1. Public Rights of Way (PRoW) run throughout the study area for the Proposed Development, providing recreation opportunities for walkers and local people, although none of the PRoW are part of recognised regional or national trails. Not all of the PRoW which intersect with the Proposed Development are considered to be impacted by it.
- 5.5.2. The local area to the Order Limits is agricultural, and so the land is mostly arable, grassy or woodland. The topsoil is predominantly clay, medium clay loam or heavy clay loam, with slowly permeable clay subsoil beneath. The land within the Panel Areas is mostly classified as Subgrade 3b, with a small amount classified as Grade 2 or Subgrade 3a. The undulating landform influences the direction of drainage in the area. Table 5-1 summarises the land classification of each Panel Area and their associated proposed cable route options.

**Table 5-1 Agricultural land and soil resource sensitivities**

Panel Area	Agricultural Land Classification			Sensitivity
	Grade 2 Ha (%)	Subgrade 3a Ha (%)	Subgrade 3b Ha (%)	
A: Brafferton	0	18.9 (16)	95.8 (84)	Low
B: Hauxley Farm	0	0	53.2 (100)	Low
C: Byers' Gill Wood	0	1.0 (1)	78.9 (99)	Low
D: Great Stainton	0	3.4 (4)	72.5 (96)	Low
E: West of Bishopton	0	0	26.5 (100)	Low
F: North of Bishopton	1.8 (3)	3.7 (5)	66.1 (92)	Low
Cable routes	0.6 (2)	0.6 (2)	34.1 (96)	Low
Total	2.4 (1)	27.6 (6)	425.5 (93)	Low

- 5.5.3. There is a safeguarded limestone mineral resource which parts of two Panel Areas cover; this only represents a small element of the overall limestone resource in the county and the limestone could be extracted following decommissioning of the solar farm.

**Plate 5-2 Indicative cross section showing proposed orchard area**



Orchard area

Existing Recreation Area

Existing Fence

Amenity Trees (at Year 15)

Amenity grassland - approx. 20m wide

Orchard Trees (at Year 15)

New Hedgerow (at Year 15)

3m wide footprint allowed for establishment of new hedgerow.

Wildflora Area - approx. 5m wide

Boundary Fence

Panel Area - panels offset from boundary fence by 3m.

Wildflora seeding proposed between panels and fence and inbetween panels.

## 6. Design evolution

### 6.1. Overarching design objectives

- 6.1.1. Informed by the ambitions of the requirements and standards for good design as established in Chapter 2 of this document, the design principles have been shaped by the site context, safety requirements of the Proposed Development and ongoing engagement and consultation with landowners, key stakeholders and members of the local community.
- 6.1.2. The design principles for the individual and specific elements of the components which make up the Proposed Development are outlined in, and controlled by, the detailed design principles and parameters established in Chapter 8 of this document. However, a summary of the overarching design objectives for the Order Limits, which were established as part of the site selection process and by which the design evolution was tested against, are provided below.
- Protect and enhance existing features characteristic of the local landscape character;
  - Develop a strong green infrastructure network and improve habitat;
  - Enhance the Public Right of Way network;
  - Protect and enhance the biodiversity within the Order Limits;
  - Enhance public amenity provision; and
  - Protect and enhance protected species.
- 6.1.3. Collectively, the design objectives and subsequent principles have helped to define and establish how the Proposed Development will fulfil the criteria of and be in accordance with the requirements of ‘good design’, as set out in the Overarching NPS EN-1 and detailed within Chapter 4 of this document.

### 6.2. Design iteration

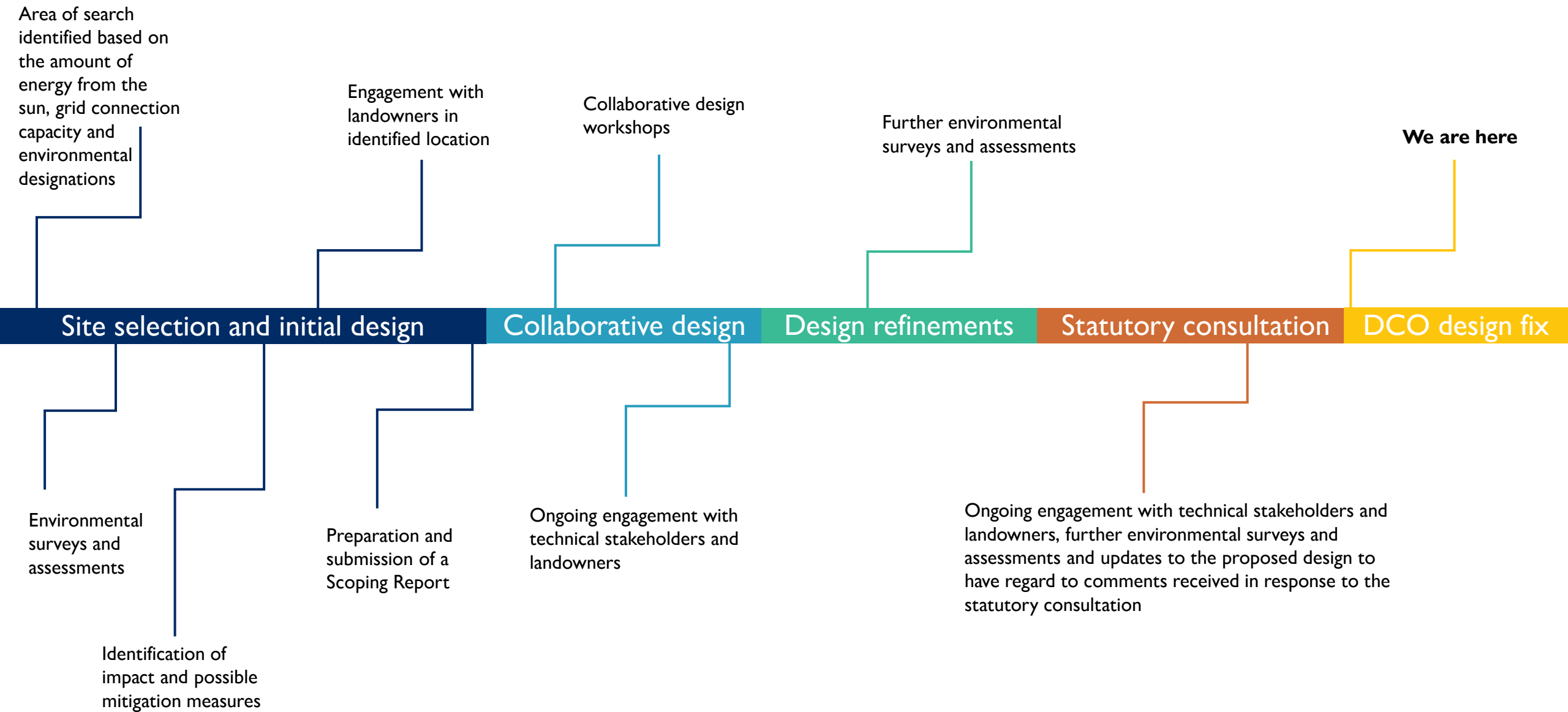
- 6.2.1. The location, design and layout of the Proposed Development has been developed taking into account a range of technical and environmental factors, as well as feedback from ongoing engagement and consultation with stakeholders, landowners and representatives of the local community.
- 6.2.2. ES Chapter 3 Alternatives and Design Iteration (Document Reference 6.2.3) provides a detailed account of the site selection and design process, which has been summarised into the timeline overleaf.

#### **Status of current design**

- 6.2.3. In recognition of the amount of local interest in the Proposed Development, the design of the Proposed Development submitted with the DCO Application, whilst preliminary in nature, is reasonably mature.

- 6.2.4. Following the presentation of and consultation on an early-stage design at the PEIR stage, the Applicant has since refined the design of the Proposed Development to have regard to the comments and concerns raised by statutory bodies, landowners and members of the local community, as evidenced in the Consultation Report (Document Reference 5.1).
- 6.2.5. In presenting the design submitted with the DCO Application, the Applicant has reflected the commitments and assurances made within the Works Plans (Document Reference 2.2) to the smallest reasonable fixed areas of land to deliver the different components of the Proposed Development.
- 6.2.6. Additionally, the Applicant recognises that there are still refinements and matters of detailed design that will be subject to further engagement and consultation with statutory bodies and local authorities. This commitment to detailed design is secured via Requirement 3 of the draft DCO (Document Reference 3.1).

**Plate 6-1 Design evolution timeline**





## 7. The Design Response

7.1.1. This Chapter (Chapter 7) focuses on the design response relating to the landscape and environmental design, and the technical infrastructure components which have been wholly or partly driven in response to the requirements of 'good design' and the existing location context.

7.1.2. It is not intended that this Chapter provides a design rationale for all elements of the Proposed Development, such as those that are constrained by safety requirements, manufacturing capabilities or industry standards and/or were not influenced by the requirements of 'good design' and the existing location context.

### 7.2. Technical infrastructure

#### Solar Panels

7.2.1. The extent of solar panels within the identified 'panel areas' has been driven by a number of offsets and buffers which were applied to the design as standard. These included:

- 30m from existing badger setts;
- 5m buffer to trees with potential for bats and bat roosting;
- 15m buffer applied to ancient and veteran trees, as well as root protection areas for all other trees;
- 8m buffer applied to watercourses and flood zones; and
- Increased set-back around Little Stainton Beck.

7.2.2. Up until the design was fixed for DCO submission, the assumption was made that the solar panels to be used across the Order Limits were to be up to 4.35m in height and would be tracked panels. This is due to a number of factors, largely that height of panel would result in the highest yield with slightly greater spacing between rows of panels, but also so that the 'worst case' scenario could be assessed and considered as part of the proposals.

**Plate 7-1 Indicative cross sections showing woodland mosaic**



Existing PRoW

Woodland Mosaic (at Year 15)

Boundary Fence

Panel Area - panels offset from boundary fence by 3m.

Wildflora seeding proposed between panels and fence and inbetween panels.

## Woodland mosaic

- 7.2.3. By considering the ‘worst case’ scenario from the beginning stages of the Proposed Development, it allowed the Applicant to present a preliminary design which included a level of flexibility and one that amends or updates could be made to in response to consultation feedback and ongoing engagement with stakeholders and landowners.
- 7.2.4. Following the statutory consultation, in response to feedback received from stakeholders, landowners and members of the local community, and following further environmental surveys and assessments, the design for the solar panels has been refined. This aligns with the NIC’s ‘people’ principle of good design, taking into account community views and the ability of people to enjoy the local area.
- 7.2.5. The Applicant has determined that a fixed solar panel system would be most appropriate for the location of the Proposed Development, responding directly to concerns raised in response to the statutory consultation. The subsequent result of that decision means:
- The maximum height of the panels has been reduced from 4.35m as proposed during statutory consultation, to a maximum of 3.5m; and
  - The configuration of the Panel Areas has been revised from a north-south alignment to an east-west alignment, facing south.
- 7.2.6. The mounting structure for the solar panels is typically fixed to the ground by galvanised steel poles which are driven into the ground to a depth of circa 1m. However, in response to geophysical and trial trenching undertaken to inform the assessment and design work, the use of an alternative mounting structure is proposed in a number of areas across the Order Limits. This alternative approach utilises ballast slabs which sit on the surface of the ground rather than penetrating the ground, thereby protecting any archaeological features in situ, and corresponding with Darlington Borough Council’s Policy ENV1 noting good design’s ability to avoid effects on heritage assets. Further detail can be found in ES Appendix 8.5 – Archaeological Management Strategy (Document Reference 6.4.8.5).
- 7.2.7. As such, the application for the Proposed Development has sought to retain a level of flexibility so that technological advances between the time of submission and the installation of the panels – should the Proposed Development be granted development consent – can be considered. This flexibility, and the parameters of that flexibility, are detailed in Chapter 8 of this document.

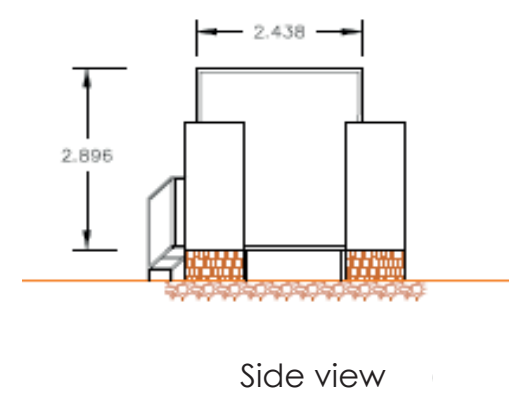
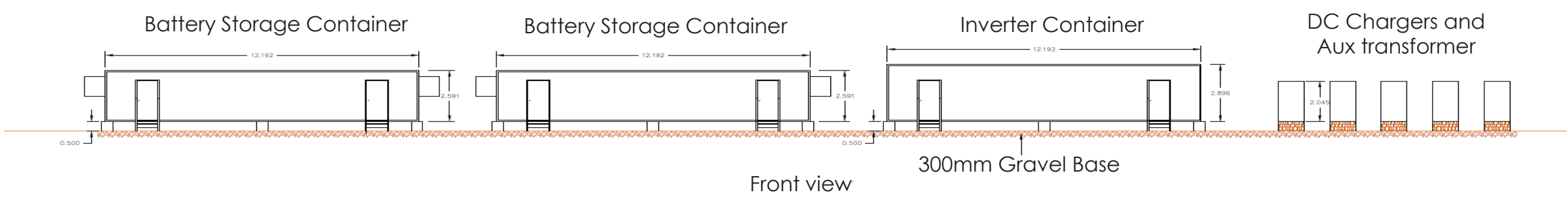
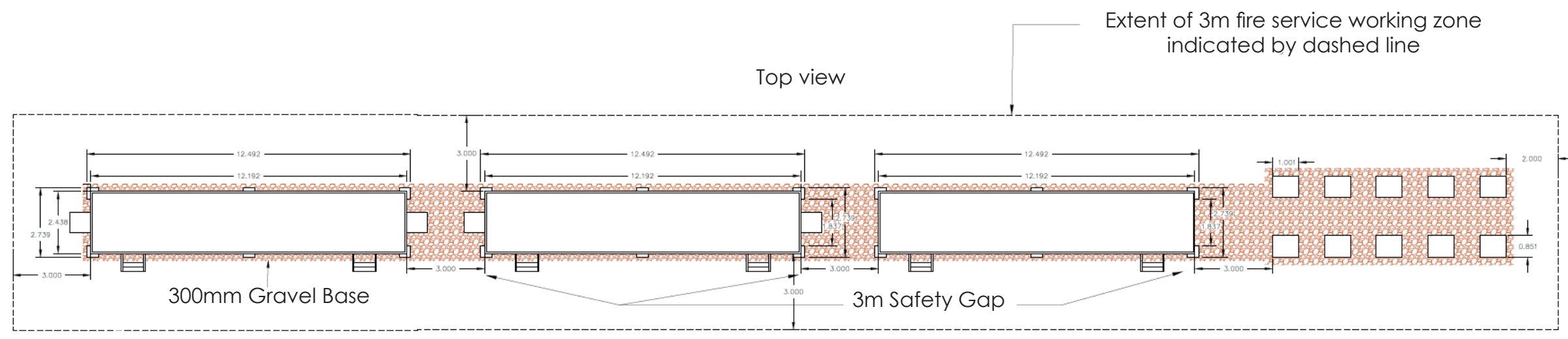
## On-site supporting equipment

- 7.2.8. A range of equipment is required to support the solar PV modules to convert the electrical power generated, manage this power and export power onto the national grid. The electrical output from the solar PV modules would be exported by low voltage cabling to shipping container style storage units which would contain an inverter, transformer and BESS. The function of each of these elements are as follows:
- inverters convert the DC generated by the solar PV modules into alternating current (AC) that can be exported to the national grid;
  - transformers monitor, increase and control the voltage of the electricity produced before it reaches the on-site substation. The transformers would be located adjacent to the inverters; and
  - BESS would comprise of containerised battery storage systems, DC-DC converter boxes and ancillary equipment
- 7.2.9. The inverters, transformers and BESS would be arranged together (“co-located”) across the Proposed Development. At this stage of design, it is anticipated that there would be up to 53 hybrid containers (which include an inverter and BESS) and up to 44 inverter containers located across the Order Limits. These would be placed on a concrete pad foundation and would measure approximately 3m in height, 2.5m in width and 12m in length, as shown overleaf. The typical layout of this supporting infrastructure and access is also provided on page 26.

**Plate 7-2 Typical transformer, inverter and BESS arrangement (Document Reference 6.2.3.10)**

Notes

1. All details are indicative only.
2. Dimensions are in metres unless stated otherwise.



P01	04/01/2024	JE	LM	TS	DB
Rev	Date	By	Chkd	Appd	Authd



Client  
 Project Name  
**Byers Gill Solar**

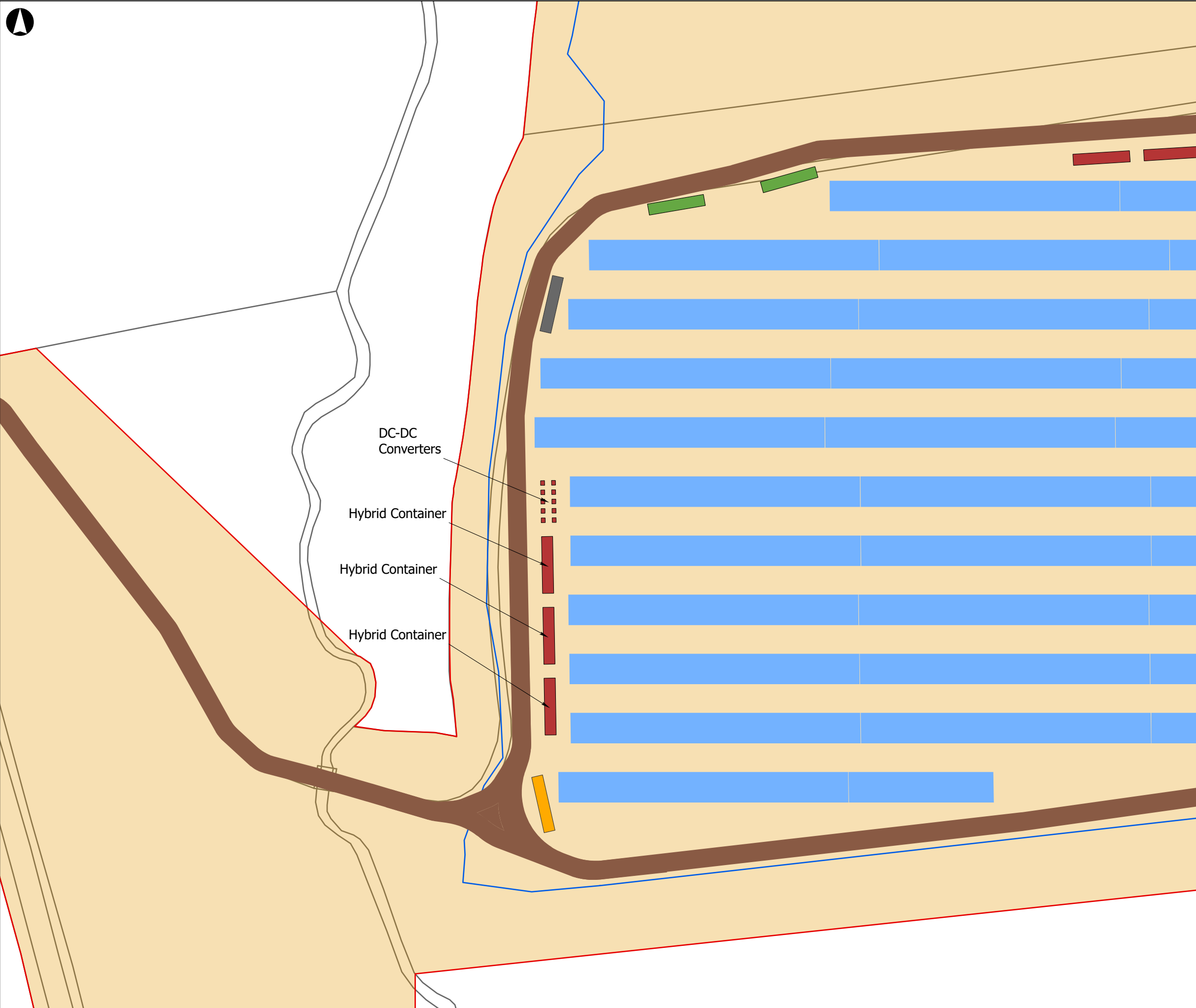
Drawing Title  
**ES Figure 2.10  
 Typical transformer, inverter and  
 BESS arrangement**

Scale at A3 <b>1:200</b>	
Role	
Issue	
Suitability	
<b>Environmental Statement</b>	
Project Number <b>286386-00</b>	Rev <b>P01</b>
Drawing Number <b>BGS-ES02-00010</b>	

- 7.2.10. The distribution of the on-site supporting equipment across the Order Limits which is shown on Plate 7-3 overleaf, has been designed in such a way that it is compliant with the industry safety requirements. Not only that, but it also aims to ensure that there is limited other environmental effects (in the spirit of NPS EN-1 and the ability of good design to mitigate adverse effects), including visual and landscape effects on residential receptors, roads and rights of way and hydrology and flood risk across the Order Limits For example:
- the BESS has been placed at least 300m from residential properties in the majority of cases, to reduce the visual and noise impact of the infrastructure;
  - the proposed siting of the BESS has been decided through engagement with the Emergency Services to ensure that proper access can be maintained throughout, whilst also reducing fire risk across the Order Limits;
  - the height of the proposed containers, do not exceed the height of the proposed screening, and where possible have been located centrally within the panel areas;
  - the areas which have been identified for the containers to be located have been done so as they can be 'hidden' within the solar panel areas; and
  - the proposed drainage system to ensure that there are no effects on surface water run-off comprises a filter drain of clean crushed stone around the BESS containers.
- 7.2.11. Therefore, it is anticipated that there will be limited environmental impacts arising from the on-site infrastructure. A detailed account of the landscape and environmental design for the Proposed Development can be found in section 7.3.

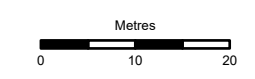


**Plate 7-3 Typical Access and Supporting Infrastructure Layout (Document Reference 6.3.2.11)**



- Legend**
- Order Limits
  - Solar PV modules
  - Hybrid containers including Battery Energy Storage Systems (BESS) and inverters
  - Inverter containers
  - Switchgear container
  - Spare containers
  - Operational access tracks
  - Fencing
  - Area for mitigation, planting, and enhancement

Coordinate System: British National Grid  
 This map is reproduced from Ordnance Survey material with the permission of Ordnance Survey on behalf of the controller of Her Majesty's Stationery Office. © Crown Copyright. Unauthorised reproduction infringes Crown copyright and may lead to prosecution or civil proceedings. LICENCE NUMBER: 0100031673 [2022]



P01	30/01/2024	JE	LM	TS	DB
Rev	Date	By	Chkd	Appd	Authd

Client



Project Name  
**Byers Gill Solar**

Drawing Title  
**Figure 2.11  
 Typical Access and Supporting  
 Infrastructure Layout**

Scale at A3  
**1:800**

Role  
**Issue**

Sustainability <b>Environmental Statement</b>	
Project Number <b>286386-00</b>	Rev <b>P01</b>
Drawing Number <b>BGS-ES02-00011</b>	

## BESS

- 7.2.12. The design and specification of the proposed BESS is subject to a number of key standards, guidelines and principals which have been established as part of the wider solar industry and associated development requirements. A detailed assessment of the safety management and mitigation measures can be found in ES Appendix 2.3 Outline Battery Fire Safety Management Plan (Document Reference 6.4.2.13). A summary of the design and associated embedded mitigation is provided below.
- 7.2.13. The BESS is likely to consist of lithium-ion batteries and will allow energy to be stored on site to ensure that there is an equal distribution of electricity across the Grid, providing a balance in services where surplus electricity is produced. BESS will be included as part of the hybrid containers, which also include auxiliary transformers and power conversion system units including invertors, switch gear, transformers required to control the BESS.
- 7.2.14. The BESS would require associated heating, ventilation and cooling (HVAC) systems to ensure efficiency of the batteries and these systems would be integrated within the individual containers.
- 7.2.15. The siting of BESS was reviewed site-wide following statutory consultation, as part of the wider design development. This was driven in part by the decision to opt for fixed 3.5m solar PV panels with an east-west alignment, which required a reconsideration of the siting of BESS to avoid design clashes. The review of this infrastructure was also undertaken following analysis of responses to statutory consultation, in which some concerns were raised regarding proximity of BESS to some residential receptors, due to concerns of noise or fire risk.
- 7.2.16. The revised siting of the BESS has resulted in the technology being located further away from residential receptors, by way of reducing the landscape and visual impact on residential and recreational receptors, corresponding with NPS EN-1's definition of good design as being sensitive to place. It is important to note that the revised siting has been done so in consultation with the local emergency services to ensure that appropriate and safe access is still provided, should it be required.
- 7.2.17. Similarly to the solar panels, the application for the Proposed Development has sought to retain a level of flexibility so that technological advances can be considered. This flexibility, and the parameters of that flexibility, are detailed in Chapter 8 of this document.

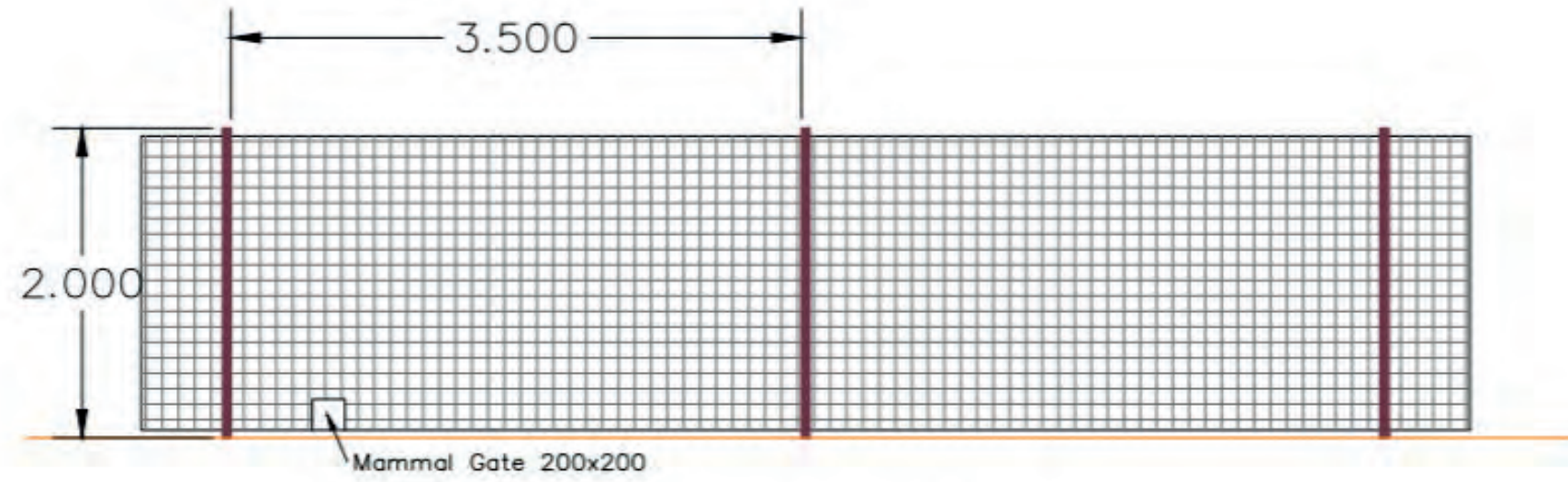
## Fencing

- 7.2.18. Primarily required for safety and security purposes, the Applicant has proposed a perimeter security fence to be installed to safely enclose the operational areas of the Proposed Development.
- 7.2.19. It is anticipated at this stage of the design that the proposed perimeter fencing would be a deer fence, with a maximum height of 2m. The maximum height of the proposed fencing has been determined partly due a reduction in the proposed height of the fixed solar panels now at a maximum of 3.5m, but also so that the proposed planting can adequately screen the perimeter fencing, reducing the visual impact of this element of the proposed Development.
- 7.2.20. Additionally, the fencing would be installed in such a way that small animals and mammals such as badgers and hares would be able to navigate between and through the panel areas, and to allow the movement of large mammals such as deer through the landscape along the retained hedgerow margins between the fencing and the highway.

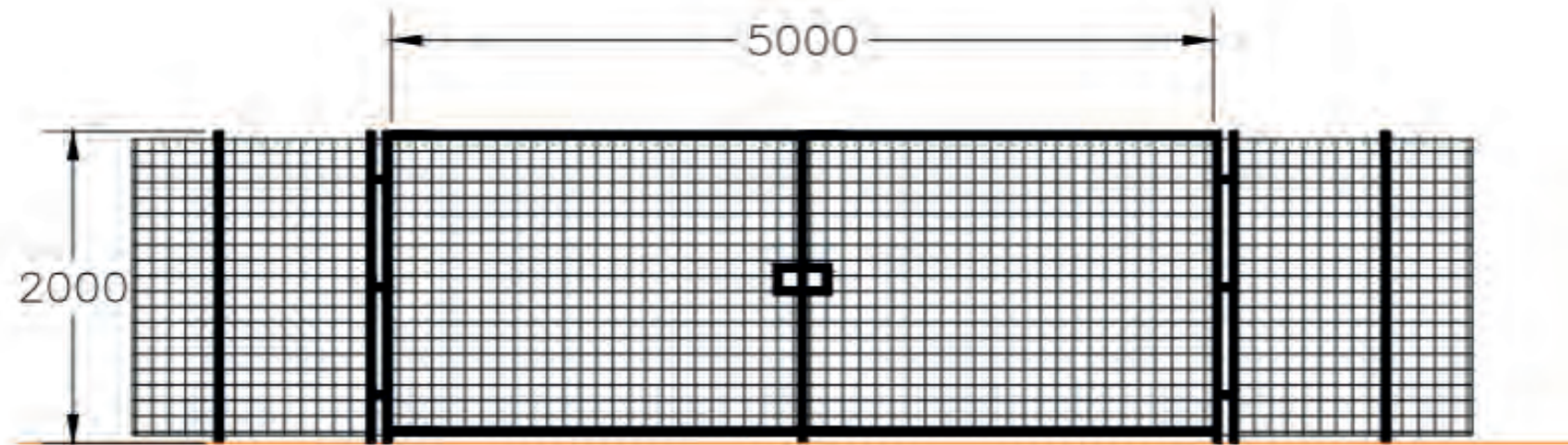
**Plate 7-4 Typical fence and gate (Document Reference 6.3.2.15)**

Notes

1. All details are indicative only.
2. Dimensions are in metres unless stated otherwise.



Timber post & wire fence



Timber post & wire gate

P01	04/01/2024	JE	LM	TS	DB
Rev	Date	By	Chkd	Appd	Authd

Client



Project Name  
Byers Gill Solar

Drawing Title

**ES Figure 2.15**  
Typical fence and gate

Scale at A3  
1:200

Role

Issue

Suitability

**Environmental Statement**

Project Number

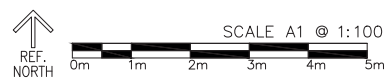
286386-00

Rev

P01

Drawing Number

BGS-ES02-00015



## Underground cabling

- 7.2.21. As a starting principle for determining cable routes, the Applicant's first preference is to avoid impacts to local communities that may be derived from utilising routes along existing roads, such as disruption to local access during the works. Avoiding routes along existing roads also has engineering and cost benefits. In comparison, it is considered that the potential for environmental impacts from using off-road routes is low considering the limited area of land required and the short-term nature of construction, with any agricultural land affected able to be returned to agriculture post-construction. Therefore, it is the Applicant's preference to avoid on-road cable routes where feasible, and this approach aligns with NPS EN-5.
- 7.2.22. In the run up to statutory consultation, the Applicant continued to engage with local landowners to identify potential easements on greenfield land to be used for the proposed cable routes. As such, as part of the statutory consultation, a network of 33kV and 132kV cable routes which utilised a combination of on-road and off-road options were identified and presented as part of the Proposed Development.
- 7.2.23. Due to the flexibility surrounding the type of cable route – on-road or off-road – the Applicant asked respondents a specific question on the proposed hybrid approach for the cable routes in the feedback questionnaire, and requested feedback on the approach taken, and to highlight any potential effects or concerns they may have.
- 7.2.24. During this time, it was anticipated that the cable routes would be refined to a single 33kV network and a single 132kV cable route for the DCO application. However, negotiations with landowners to secure the necessary land rights via agreement for off-road cable routes (the preferred option) are ongoing at the time of submission. Consequently, there is a need to retain flexibility in options in order to ensure the deliverability of the Proposed Development and the Order Limits includes land for both on-road and off-road routes, should compulsory acquisition powers not be granted. The final routing of the underground cables will be determined post-consent and approved via requirement 3 of the draft DCO (Document Reference 3.1).
- 7.2.25. The main factors behind the preference for off-road cable routes are listed below and are considered fully in ES Chapter 3 Alternatives and Design Iteration (Document Reference 6.2.3):
- a. Length and routing of cable – the preferred option provides a more direct routing between panel areas and from the on-site substation to the national grid, resulting in a reduced amount of materials required and removal and replacement of highway materials.
  - b. Cost and programme – the preferred option would result in approximately 50% savings when compared to an on-road cable route. It would also enable a quicker construction programme, saving approximately 10 days per km when compared with on-road cable installation.
  - c. Construction impacts – an on-road cable route would result in the need for temporary traffic measures throughout the construction period and for any maintenance and management activities, resulting in disruption to the local road and public right of way network.

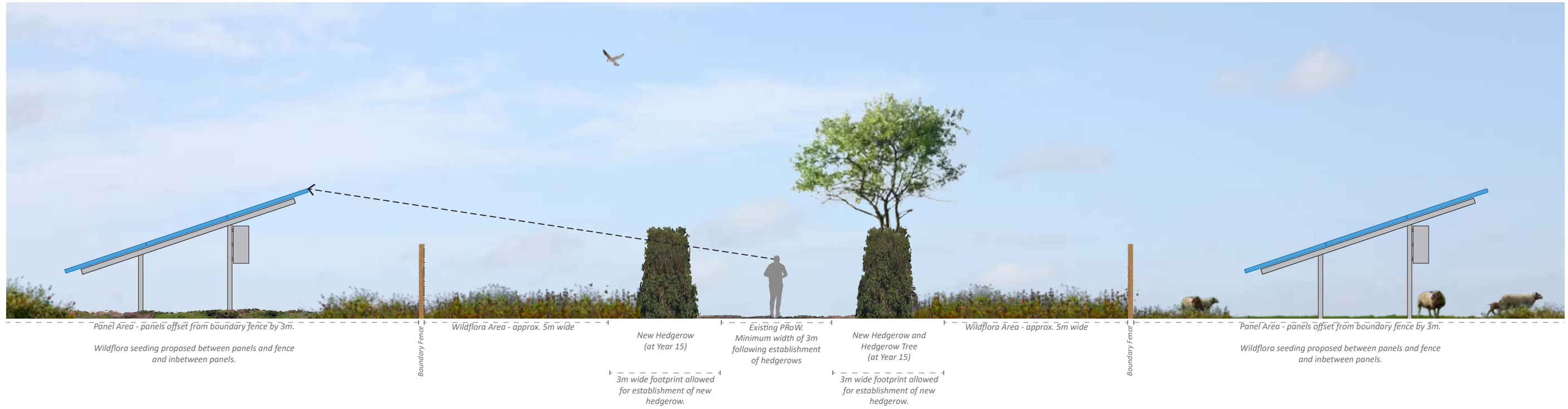
- d. Consultation feedback – as identified in the Consultation Report (Document Reference 5.1), disruption to local communities resulting from cable installation was a key theme raised in response to the statutory consultation, as well as any potential impacts on Bishopton Conservation Village during the installation process.

## **CCTV**

- 7.2.26. CCTV columns would be placed between the fencing and the solar PV modules, and oriented to look along the gap rather than beyond the Panel Areas. These CCTV columns would be no more than 3. in height;
- 7.2.27. Pole-mounted, infra-red security detection cameras would be mounted on poles of up to 3m in height located within the perimeter fence. It is anticipated that these cameras would have motion detection technology for recording and would be pointed directly within the Order Limits and away from any land outside of the Order Limits. A typical CCTV pole is shown in ES Figure 2.16 (Document Reference 6.3.2.16);
- 7.2.28. In relation to visual effects specifically, as reported in ES Chapter 7 Landscape and Visual (Document Reference 6.2.7), the CCTV cameras would be no taller than the solar panels and included within the panel fields. It is therefore considered that they would not have markedly different effects on views and character to those of the other elements (panels, inverters, storage) of similar height within the panel areas.



**Plate 7-5 Indicative cross section showing public rights of way**



A - Public right of way with hedgerow



B - Public right of way with interpretation board

## 7.3. Landscape and environmental design

7.3.1. The landscape and environmental design of the Proposed Development has been guided by the overarching design objectives as described in Section 6.1.2. which were established as part of the site selection process. The design outcomes have been separated into three themes which relate primarily to either People, Place and Environment. These themes tie in with the proposed Management Opportunities as described within the Outline Landscape and Ecology Management Plan (LEMP) (Document Reference 6.4.2.14). They are not mutually exclusive, indeed there is strong evidence that access to quality green space and the natural environment can result in improvements to health and wellbeing of people. Hence there is some overlap within the three themes as they are set out below, as, wherever possible, improvements in one theme can have a commensurate positive effect to another.

### People

7.3.2. The Proposed Development has been designed to respect the amenity of local residents and communities by giving consideration to environmental impacts. The design process has involved the identification of local residents likely to be impacted and has incorporated mitigation in the form of setbacks from development and/or buffer planting to mitigate effects wherever practicable. Ancillary equipment, such as inverter cabins, BESS and the substation have largely been located away from people, whilst potentially intrusive elements such as security fencing have been designed to sit comfortably within the agricultural landscape; this has been achieved by the location of structures in association with existing hedgerows and woodland buffer features wherever possible. Further mitigation would be provided by painting equipment in recessive colours to avoid drawing attention to them whilst woodland and scrub planting around infrastructure is intended to provide screening benefits for local residents and users of P<sub>RoW</sub> and roads (in the spirit of Darlington Borough Council's Policy DC1 which requires good design to create attractive and desirable places).

7.3.3. The Proposed Development has been designed to ensure existing access and local amenity areas are safeguarded. This has been achieved through consultation with key stakeholders, the Local Planning Authorities (LPAs) and local communities – as demonstrated in the Consultation Report (Document Reference 5.1) - in order to identify opportunities to improve the quality, access to and connectivity of the existing P<sub>RoW</sub> network. In addition, opportunities to create new permissive routes linked to green networks and existing access routes have been identified to provide increased linkage and solutions to currently difficult to access P<sub>RoW</sub>, according with the 'people' principle of the NIC's Good Design Principles.

7.3.4. This principle is further reflected in the design as it has considered the experience of recreational receptors and has sought to enhance their enjoyment by creating new green corridors with improved biodiversity value, together with opportunity for interpretation and education of the solar farm and any historic and biodiversity features of the Site. Elsewhere, existing long-range or panoramic views from P<sub>RoW</sub> have been

protected wherever possible, with planting in buffers and hedgerows to be maintained at lower levels and or set further back from the routes in some locations in order to retain views.

## Place

- 7.3.5. The Proposed Development has been designed to preserve and where possible enhance local landscape features and give consideration to providing greater access to enable their appreciation, according with NPS EN-1's requirement for infrastructure to be sensitive to place. This has been achieved by identifying key landscape features and opportunities from national and regional landscape character studies and from Darlington's Green Infrastructure proposals.
- 7.3.6. In order to enhance educational opportunities and celebrate the richness of the surrounding landscape, suitable locations for interpretation boards to provide information on the historic, archaeological and biodiversity features of the Site have been included on the Environmental Masterplan (Document Reference 2.5).
- 7.3.7. Additionally, new amenity areas are proposed in the form of informal recreation and interpretation of historical features such as the WWI airstrip and Motte and Bailey Castle to the south of Bishopton. Further ecological amenities are also proposed, including a new community orchard connected to the recreation area to the eastern edge of Bishopton and the addition of a 'Forest School' and 'Sensory Garden' at Bishopton Primary School.

## Environment

- 7.3.8. The Proposed Development corresponds with the idea of good design in NPS EN-1 through creating a sustainable design and meeting other NPS policy objectives, and with the NIC's 'places' Good Design Principle by making a positive contribution to ecology. It has sought to retain existing trees and hedgerows wherever reasonably possible to maintain the landscape fabric of the Site and aid the development's assimilation into its surroundings.
- 7.3.9. The design of the Proposed Development builds on the existing habitats identified through ecological surveys in order to increase their value for wildlife. This will include new planting to improve habitat and food resource for wildlife, taking particular consideration of pollinating species and birds during winter months. Areas of no development (i.e. identified as Biodiversity Enhancement Areas on the Environmental Masterplan) have been identified and will be protected.
- 7.3.10. Extensive hedgerow and hedgerow tree planting is intended to strengthen green corridors and to create links between existing woodland belts or copses to achieve a green network. The proposed grassland diversification under and between solar panels to deliver biodiversity benefit for pollinators and farmland birds will also encourage linkage of wildlife sites within the Site and its surroundings. Particular emphasis has

been placed on improving local Corridor Buffers as part of Darlington's GI Strategy Action Plan<sup>5</sup>.

- 7.3.11. The grassland diversification also involves using the land in a manner that will improve soil health by allowing fields to rest, reduce fertiliser and herbicide inputs with potential to maintain some agricultural productivity. This will also benefit and protect existing waterways and ditches within the Site.
- 7.3.12. As described in the Outline LEMP (Document Reference 6.4.2.14), existing habitats identified through ecological surveys will be managed to increase their value for wildlife. Locally native species will be used to create new habitats wherever possible with species that provide a food resource for local wildlife species, such as those that are fruit bearing or that have a long pollination period. Other features will include the introduction of bird and bat boxes, hibernacula (for amphibian refuge) and insect hotels. The purpose of the design is to greatly exceed the BNG mandatory target of 10%.
- 7.3.13. The proposed new habitat creation and enhancement we would provide is expected to have long-term, beneficial impacts on the area, with an anticipated significant net gain in biodiversity of 88% in habitat biodiversity units and a 108% net gain in hedgerow biodiversity units. More information on our assessment of the impacts on biodiversity can be found in ES Appendix 6.6 Biodiversity Net Gain Report (Document Reference 6.4.6.6).

---

<sup>5</sup> [Layout 1 \(darlington.gov.uk\)](https://www.darlington.gov.uk)

**Plate 7-6 Indicative cross section showing picnic area**



## Picnic area with sculpture

## 7.4. Outcomes of the design response

- 7.4.1. The design response has resulted in embedded mitigation measures incorporated into the design as described in Section 6.1. Embedded mitigation is reported in the Environmental Statement (ES). Further essential mitigation, beyond that embedded in the Proposed Development, is also described in the ES. These various mitigation measures proposed to prevent, reduce or compensate likely significant adverse effects have been identified as part of the iterative design process.
- 7.4.2. The landscape design process has been informed by a desktop review of plans, maps, aerial photography, policy documents and published baseline landscape character assessments; as well as a site visits and design review workshops. The process identified a number of mitigation measures to be embedded in the Proposed Development design, which align with the mitigation hierarchy by preventing and reducing impacts. These are as follows:
- Reductions to the extent of the Panel Areas to mitigate effects on villages and views from homes;
  - Reduction in the heights of the panels (to 3.5m from the 4.35m proposed at the PEIR stage);
  - Planting of tree lines along northern boundaries of the Panel Areas to reduce visibility from residential and recreational receptors;
  - Re-routing of some footpaths that would pass through panel areas;
  - New hedgerow planting where existing hedgerows are sparse or where the Panel Area edge does not coincide with an existing field boundary;
  - The proposed community orchard adjacent to Bishopton recreation ground and school to provide both mitigation and a community facility.
- 7.4.3. Embedded enhancement measures include the provision of biodiversity enhancements and recreational opportunities which contribute positively to landscape value. Further information can be found in the Mitigation Route Map (Document Reference 7.7).
- 7.4.4. Chapter 7 Landscape and Visual of the ES (Document Reference 6.2.7) identifies that even with the above mitigation measures, some effects that are considered significant in EIA terms would remain. These are detailed in Table 7-1 below, supported by a design response and explanation as to why these significant residual effects cannot be further mitigated or reduced in this scenario. As noted in Section 4.2, NPS EN-1 sets out that for CNP infrastructure such as solar farms, residual impacts remaining after application of the mitigation hierarchy are unlikely to outweigh the urgent need for its development.



**Table 7-1 Residual significant landscape and visual effects**

Location and stage of effect	Description of effect	Explanation for remaining significant residual effect
Effects on the character of Bishopton during construction	These effects would only arise if the on-road cable route is used for the Proposed Development.	The Applicant has stated a clear preference in the DCO application for off-road cable routes wherever possible. These are depicted in ES Figure 2.13 (Document Reference 6.3.2.13). Cable route options have been developed taking into account factors such as environmental constraints, technical feasibility and cost.
Effects on the character of, and views from, Bishopton during early operation	These effects would arise until mitigation planting to screen views of Panel Area F from Mill Lane and the recreation ground matures. Along Mill Lane the mitigation proposed is to allow existing hedges to grow taller and this mitigation would be effective in approximately 3 years.	New planting (community orchard) is proposed to screen views from the recreation ground and will take longer to reach sufficient height and density to fully screen views. The inclusion of two hedges, and semi-mature trees within the community orchard will assist in increasing early screening by 'layering' the planting, though winter views will remain relatively open for 6-10 years. Denser planting may have taken effect more quickly but would not have been as suitable as an enhancement to local access and amenity.
Effects on the character of LCA Darlington 6: Great Stainton Farmland during operation	This is the host landscape character area for panel Areas A to D.  The panels would occupy a notable extent of the character area and this physical extent gives rise to significant effects.	Irrespective of the screening planting provided to mitigate the effects on LCA Darlington 6: Great Stainton farmland, due to the scale of the Proposed Development, it would not be feasible or possible to fully mitigate or reduce the significance of this effect felt during the operational stage of the Proposed Development.
Effects on the character of, and views from, Great Stainton during operation	Great Stainton occupies a distinctive elevated position in the landscape with a strong visual interrelationship with the open lower-lying landscape to the south and east. Panel Area D would lie on the slopes which rise up towards the village and would be within the topographic setting of the village.	Tree planting to screen the panels in outward views from the village would increase adverse effects on character and views by removing the open views, and further planting would not markedly reduce visibility of the panels from the lower lying landscape due to the location of the panels on sloping higher ground.
Effects on public rights of way within 1km of the Panel Areas during construction and operation	There is a dense network of public rights of way within the landscape within 1km of the Panel Areas that would experience a change in views.	The landscape is undulating and planting cannot entirely prevent close views of solar panels and/or enclosure of previously open views by hedgerows (which in itself gives rise to significant effects).  It is not conclusive that each public right of way within 1km of the proposed panels areas will result in a significant landscape and visual effect, however the Applicant has taken a holistic approach to the assessment, and therefore considered a worst-case scenario.

- 7.4.5. Table 7-1 above identifies that following the implementation of the mitigation hierarchy as defined in NPS EN-1, and the provision of recreational, amenity, ecological and connectivity mitigation measures, few significant landscape and visual effects remain. At this stage, it is considered that the only remaining way in which the significance of effects could be reduced, is to in-part or wholly remove one or more of the proposed Panel Areas.
- 7.4.6. The scale of the proposed development is defined by the capacity available on the National Grid. The Applicant has an agreement with Northern Power Grid to supply 180MW of electricity from solar power to the Norton Substation. The area of land proposed, which was reduced following consultation, is required to produce the generating capacity.
- 7.4.7. As outlined within the Planning Statement (Document Reference 7.1), most of the effects would be reversible following decommissioning. The temporary, 40-year operational period of the Proposed Development is secured via the DCO (Document Reference 3.1).
- 7.4.8. After decommissioning, the Proposed Development would leave a positive legacy of improved landscape fabric and character due to the denser hedgerows and maturing trees which would be left after the lifetime of the operational development. This may result in the enclosure of currently open views, however after the operational lifetime of the Proposed Development, hedges could be reverted to lower heights to allow outward views over them if that is judged desirable.
- 7.4.9. The significant landscape and visual impacts which remain are those which could only be mitigated by removing large parts of one or more of the Panel Areas.
- 7.4.10. A summary of other significant residual effects is presented in Chapter 14 Summary of the ES (Document Reference 6.2.14). During construction these include for land use and socioeconomics (associated with temporary loss of agricultural land and soil resource), and noise and vibration (temporary/short term and reversible); during operation for climate change (beneficial); and during decommissioning for land use and socioeconomics (beneficial, associated with return of agricultural land and soil resource to use); and noise and vibration (temporary/short term and reversible).

## 7.5. Summary

- 7.5.1. The Applicant understands that the Proposed Development will change the landscape from its current form. It also acknowledges the value of this landscape to the local community, which was clear from the response to the consultation and engagement. From the inception of the project, the opportunity to create a solar farm that allows for interpretation of its place in the changed landscape, and that enhances the experience of the surrounding landscape, and its heritage, has been a central part of the design's iteration. The measures proposed to achieve this include the preservation and enhancement of public rights of way, provision of amenity spaces for use by the community including those specifically designed for the school, and by delivering biodiversity net gain across the site.
- 7.5.2. In considering how the proposed development will play a wider role in preserving the landscape by mitigating the much greater impacts of climate change, the Applicant has sought to ensure that it is permeable to its place, and can be experienced as a temporary phase in this places' story.

## 8. The Design Parameters

### 8.1. Introduction and definitions

- 8.1.1. This table should be read in conjunction with Schedule 1 of the draft DCO (Document Reference 3.1), which provides further definitions of the works as relevant. Key definitions are replicated below for convenience:
- 8.1.2. “balance of solar plant” means inverters, transformers, and switch gear and would be either—
- (a) *solar stations being a station comprising centralised inverters, transformers and switch gear with each component for each solar station either—*
    - (i) *a “solar station” located outside, with a concrete foundation slab or placed on metal skids for each of the inverters and transformers and switch gear; or*
    - (ii) *housed together within a container sitting on a concrete foundation slab or placed on metal skids; or*
  - (b) *String inverters attached either to mounting structures or a ground mounted frame switchgear and transformers on a concrete foundation slab or placed on metal skids;*
- 8.1.3. “electrical cables” means-
- (c) *cables of differing types and voltages installed for the purposes of conducting electricity, auxiliary cables, cables connecting to direct current (DC) boxes, earthing cables and optical fibre cables;*
  - (d) *excavations to install trenching, including storage of excavated material;*
  - (e) *provision of ducting or alternative means of conducting media including jointing pits hardstanding adjoining the jointing pits, combiner boxes, fibre bays, cable ducts, cable protections, joint protection, manholes, kiosks, marker posts, underground cable marker, tiles and tape, send and receive pits for horizontal directional drilling, trenching, lighting, and a pit or container to capture fluids associated with drilling;*
- 8.1.4. “solar panel” means
- a solar photovoltaic panel or module designed to convert solar irradiance to electrical energy;
- 8.1.5. “substation” means
- a substation containing electrical equipment required to switch, transform, convert electricity and provide reactive power compensation;

## 8.2. Design Approval

- 8.2.1. Requirement 3 of the Draft DCO outlines that no phase of the authorised development may commence until details of the various aspects of the proposed development have been submitted to and approved in writing by the relevant planning authority.
- 8.2.2. In preparing this detailed design, the Applicant must accord with the location plan, works plans, environmental masterplan, principles and assessments set out in the ES and this Design Approach Document.
- 8.2.3. The authorised development must then be carried out in accordance with the approved details.
- 8.2.4. The Applicant recognises the value of engaging with an independent design body as part of the detailed design process and proposes to engage with the Design Council prior to seeking formal discharge of the Requirement and approval of the detailed design with the LPA. The outcome of this engagement would be recorded and included in the final Requirement submission to the LPA for consideration as part of the approval process.
- 8.2.5. Additionally, the Applicant, in line recent PINS guidance will appoint a ‘Design Champion’ as part of the detailed design process. This will be a director or other senior employee at RWE with responsibility for the project. The Design Champion will ensure compliance with the parameters set, as well as providing broader design governance to ensure that good design outcomes are delivered, which are specific and proportionate to the type of infrastructure proposed.

## 8.3. Design parameters

**Table 8-1 Design parameters**

Element of Proposed Development	Parameter type	Design principle
<p><b>Work No. 1 – a ground mounted solar photovoltaic generating station comprising—</b></p> <p>Work No. 1A, 1B, 1C, 1D, 1E, and 1F: being Panel Areas A to F, comprising:</p> <p>(a) solar panels fitted to mounting structures;</p> <p>(b) balance of solar plant</p>		
<b>Solar panels fitted to mounting structures</b>	Location	The solar panels will be located as shown in locations of Work No.1 on the Works Plans (Document Reference 2.2)
	Design	The solar panels will be positioned on the mounting structures at an angle of between 10 and 30 degrees from horizontal.
	Design	The solar panels will slope towards the south.
	Layout	There will be a minimum of 4m and maximum of 12m distance between the solar panel rows.

Element of Proposed Development	Parameter type	Design principle
	Scale	The maximum height of the solar panels will be 3.5m. This includes locations where panels are raised above the 1 in 1000 year flood depth.
	Scale	The minimum height of the lowest part of the solar panels (i.e. not including the mounting structure) will be 0.8m. Solar panels will be raised sufficiently above the 1.0% AEP flood level and not impede overland flow routes.
	Design	The mounting structure for the solar PV modules will be a metal frame (usually anodised aluminium alloy).
	Scale	The mounting structures will be fixed to the ground by galvanized steel poles which are typically driven into the ground to a depth of approximately 1m. This will avoid interaction with the water table.
	Design	In locations with archaeology constraints, the mounting structure will be ballast slabs which sit on the ground surface. Locations of archaeology constraints are to be identified through further site investigation as set out and secured in ES Appendix 8.5 Archaeological Management Strategy (Document Reference 6.4.8.5).
	Layout	The layout of the Panel Areas enables the retention of woodland and the majority of hedgerows and associated trees.
	Layout	A 10m buffer will be maintained between solar panels and riparian boundaries and watercourses, comprising of 8m buffer from the perimeter of the watercourse and 2m infrastructure offset from the fencing.
	Design	An 8m buffer will be maintained between solar panels and hedges to retain foraging and commuting corridors for bats. This will be 3m from hedgerows to security fencing and 5m from security fencing to solar PV cells.
	Layout	Appropriate buffers will be maintained between solar panels and trees with potential bat roost features, in line with British Standard BS 5837 by establishing a Construction Exclusion Zone (CEZ) around their Root Protection Areas (RPA).
	Layout	Solar PV modules have been excluded from areas close to homes to mitigate potential effects on residential visual amenity and from some parts of the Panel Areas in order to mitigate effects on the views from and character of Brafferton, Bishopton and Great Stainton
<b>Balance of solar plant</b>	Location	The balance of solar plant will be located as shown in locations of Work No. 1 on the Works Plans (Document

Element of Proposed Development	Parameter type	Design principle
		Reference 2.2), which are co-located with the BESS forming Work No. 2.
	Location	Inverters and batteries would be located amongst the solar panels throughout the Panel Areas.
	Location	Critical infrastructure (such as electrical switchgear) is located outside of the flood zones.
	Location	Inverters and any other sources of noise will be located as far as reasonably possible from existing sensitive receptors, and at a minimum distance of 300m from existing sensitive receptors.
	Scale	The balance of solar plant containers will be up to 3m in height, up to 2.5m in width and up to 12m in length.
	Design	There are no permanent buildings within Work No.1 of the Proposed Development.
	Scale	There will be 44 inverter containers.
	Design	The containers will have a grey finish.
	Design	The balance of solar plant containers will utilise concrete pad foundations.
<p><b>Work No. 2 – a battery energy storage system comprising:</b></p> <ul style="list-style-type: none"> <li>(a) battery energy storage system units co-located with Work No. 1;</li> <li>(b) auxiliary transformers and associated bunding;</li> <li>(c) power conversion system units including inverters, switch gear, transformers and ancillary equipment;</li> <li>(d) containers or enclosures housing all or any of Work Nos. 2(b) and (c) and ancillary equipment sitting on a concrete foundation slab or placed on metal skids;</li> <li>(e) monitoring and control systems;</li> <li>(f) heating, ventilation and air conditioning systems;</li> <li>(g) fire safety infrastructure including water storage in tanks or other containers, and drainage and water containment features and associated infrastructure; and</li> <li>(h) containers or similar structures to house control and welfare facilities, and storage.</li> </ul>		
<b>Battery energy storage system (BESS)</b>	Location	The BESS will be located as shown in locations of Work No. 2 on the Works Plans (Document Reference 2.2), which are co-located with the solar panels forming Work No. 1.
	Location	Inverters and batteries would be located amongst the solar panels throughout the Panel Areas.
	Location	Critical infrastructure (such as electrical switchgear) is located outside of the flood zones.
	Location	Inverters and any other sources of noise will be located as far as reasonably possible from existing sensitive receptors, and

Element of Proposed Development	Parameter type	Design principle
		at a minimum distance of 300m from existing sensitive receptors.
	Scale	The BESS containers will be up to 3m in height, up to 2.5m in width and up to 12m in length.
	Scale	There will be up to 53 hybrid containers, containing an inverter and BESS.
	Design	There are no permanent buildings within Work No.2 of the Proposed Development.
	Design	The containers will have a grey finish.
	Design	The BESS containers will utilise concrete pad foundations.
	Design	The BESS will require heating, ventilation and cooling systems which will be integrated within the individual containers.
<b>Storage containers</b>	Scale	Up to nine additional storage containers will be installed to contain extra equipment to support maintenance activities.
	Design	The storage units will resemble shipping containers.
<p><b>Work No. 3– works including:</b></p> <ul style="list-style-type: none"> <li>(a) 33 kilovolt electrical cables connecting Work No. 1 and Work No. 2 to Work No. 4;</li> <li>(b) 132 kilovolt electrical cables connecting Work No. 4 to Work No. 6 within Panel Areas;</li> <li>(c) fencing, gates, boundary treatment and other means of enclosure;</li> <li>(d) improvement, maintenance and use of existing private tracks;</li> <li>(e) laying down of internal access tracks, ramps, means of access, footpaths, permissive paths, roads, including the laying and construction of drainage infrastructure, signage and information boards;</li> <li>(f) works for the provision of security and monitoring measures such as CCTV columns, lighting columns and lighting, cameras, weather stations, communication infrastructure, and perimeter fencing;</li> <li>(g) landscaping and biodiversity mitigation and enhancement measures including planting;</li> <li>(h) works required for crossing, moving re-routing or over/undergrounding of existing utility assets (including water, gas, sewer pipes, electricity distribution/transmission cabling, telecommunications etc.).</li> </ul>		
<b>33kV electrical cabling</b>	Location	The 33kV underground cabling will be located in the area of Work No.3 on the Works Plans (Document Reference 2.2).
	Design	Cabling from the solar panels to the inverters will be fixed to the mounting structures above ground. A small section will be placed underground where it leaves the solar panel and connects to the inverters.
	Location	Where 33kV cables are outside of the Panel Areas the preference is to use off-road routes. If it is not possible to deliver off-road cable routes, on-road routes would be used.



Element of Proposed Development	Parameter type	Design principle
	Design	A cable plough will be used for off-road routes. If this is not possible, other methods such as conventional trenching or horizontal direction drilling (HDD) will be used.
	Layout	Cables will be located in existing gaps in hedgerows wherever feasible.
<b>132kV electrical cabling</b>	Location	Parts of the 132kV cable routes will be located within Panel Areas and those are shown as Work No 3 on the Works Plans (Document Reference 2.2). The parts of the 132kV cable routes which are outside the Panel Areas form Work No. 5.
	Design	A cable plough will be used. If this is not possible, other methods such as horizontal direction drilling (HDD) will be used.
	Scale	The maximum dimension of the cable trench would be 1600mm depth x 2000mm wide.
<b>Fencing and gates</b>	Location	The fencing associated with Work No.3 will be located as shown in the area of Work No.3 on the Works Plans (Document Reference 2.2).
	Scale	The fencing will have a maximum height of 2m.
	Design	The fence is likely to be a deer fence. The fence would be designed in such a way to allow small animals to pass through.
	Design	The fence will be gated.
<b>Access tracks</b>	Location	The access tracks associated with Work No.3 will be located in the area of Work No.3 on the Works Plans (Document Reference 2.2).
	Location	Where possible, access tracks are to be located outside of flood zones. Where tracks are located within the flood zone they will remain at grade to ensure there is no loss of flood plain.
	Location	The access tracks will be located towards lower quality land available (that in Subgrade 3b quality) wherever possible.
	Location	The access tracks will be located to pass through existing gates and gaps in hedgerows where feasible.
	Design	The access tracks will be permeable to allow water to filtrate through and maintain greenfield runoff rates.
	Design	Any small impermeable areas will have an apron of clean crushed stone to promote natural land drainage conditions in the vicinity of the structures. The apron will be at least 1m wide beyond the structure footprint with a depth of at least 300mm consisting of 40-70mm crushed stone.

Element of Proposed Development	Parameter type	Design principle
<b>Drainage</b>	Location	The drainage associated with Work No.3 will be located in the area of Work No.3 on the Works Plans (Document Reference 2.2).
	Design	Detailed operational drainage design will be undertaken prior to construction.
	Design	Sustainable drainage solutions (SuDS) will be provided at source, ensuring that surface water run-off is managed consistently with existing site conditions.
	<u>Design</u>	<u>Provide enhancement at Panel Area F between solar panel area and Mill Lane, within 60m wide buffer street. Provision of a bund and/or swale (shallow storage ditch).</u>
	<u>Design</u>	<u>Provide enhancement at junction of Folly Bank Road and The Green within buffer areas adjacent to Panel Areas E02 and E03 as shown on Figure 1.2 of the Flood Risk Assessment and Drainage Strategy (Document Reference 6.4.10.1, Revision 5).</u>
<b>Pole mounted CCTV</b>	Location	Pole-mounted CCTV will be located in the area of Work No.3 on the Works Plans (Document Reference 2.2).
	Design	Infra-red security detection cameras will be mounted on poles.
	Scale	The poles will have a maximum height of 3m.
	Design	The cameras would have motion detection technology for recording.
	Design	The cameras will be pointed directly within the Order Limits and away from any land outside of the Order Limits.
<b>Lighting</b>	Location	Lighting will be located in the area of Work No.3 on the Works Plans (Document Reference 2.2).
	Design	Sensor triggered infra-red security lighting will be located around key electrical infrastructure; the lighting will not be continuous.
	Design	Lighting will be directed toward the middle of the working area and will utilise directional fittings to minimise outward light spill and glare, preferably at an angle greater than 20 degrees from the horizontal.
<b>Laying down of permissive paths, signage, and information boards</b>	Location	The routing of permissive paths will be as per those shown on the Street Works, Rights of Way and Access Plan (Document Reference 2.3).
<p><b>Work No. 4 – works in connection with an onsite substation comprising:</b></p> <p>(a) substation, switch room buildings, concrete foundations and ancillary equipment including reactive power units;</p>		

Element of Proposed Development	Parameter type	Design principle
<p>(b) power conversion system units including inverters, switch gear, transformers and ancillary equipment;</p> <p>(c) control building housing offices, storage containers and space, welfare facilities, waste storage within a fenced compound, car parking;</p> <p>(d) monitoring and control systems for Work Nos. 1, 2 and 4;</p> <p>(e) 132 kilovolt harmonic filter compound;</p> <p>(f) electrical cables;</p> <p>(g) communications mast being not more than 15 metres in height;</p> <p>(h) deluge system including water tanks and fire suppression, and drainage and water containment features and associated infrastructure; and</p> <p>(i) access gates and tracks, security palisade fencing and bunding.</p>		
<p><b>Onsite substation</b></p>	Location	The onsite substation will be located as shown as Work No 4 on the Works Plans (Document Reference 2.2).
	Location	The onsite substation has been located on lower quality land available (that in Subgrade 3b quality).
	Scale	The onsite substation will be up to 70m in width and will be up to 70m in length.
	Scale	The highest electrical equipment will be 8m in height.
	Scale	The communications tower will have a maximum height of 15m.
	Scale	The parking and turning area will be up to 30m x 70m.
<p><b>Work No. 5 – works including:</b></p> <p>(a) 132 kilovolt electrical cables connecting Work No. 4 to Work No. 6 outside Panel Areas;</p> <p>(b) fencing, gates, boundary treatment and other means of enclosure;</p> <p>(c) laying down of internal access tracks, ramps, means of access, footpaths, roads, including the laying and construction of drainage infrastructure, signage and information boards; and</p> <p>(d) works required for crossing, moving re-routing or over/undergrounding of existing utility assets (including water, gas, sewer pipes, electricity distribution/transmission cabling, telecommunications etc.)</p>		
<p><b>132kV electrical cabling</b></p>	Location	The 132kV cable routes which are outside of the Panel Areas will be located as shown as Work No 5 on the Works Plans (Document Reference 2.2).
	Location	Where 132kV cables are outside of the Panel Areas the preference is to use off-road routes. If it is not possible to deliver off-road cable routes, on-road routes would be used.
	<u>Location</u>	<u>If the cable goes off-road to the south of Carlton as shown on Sheet 12 of 13 of the Works Plans [CR1-003], the route would avoid the existing SuDS feature / attenuation pond located to the south east of Cleveland Drive.</u>

Element of Proposed Development	Parameter type	Design principle
	Design	A cable plough will be used for off-road routes. If this is not possible, other methods such as horizontal direction drilling (HDD) will be used.
	<u>Design</u>	<u>Where the cable crosses an area of Open Space land, as shown on the Special Category Land Plans (Document Reference 2.6), any associated works will ensure that the recreational route that runs on the former / dismantled railway line is kept open, either through localised management or through use of Horizontal Directional Drilling (HDD) of the cable.</u>
	Scale	The maximum dimension of the cable trench would be 1600mm depth x 2000mm wide.
<b>Fencing and gates</b>	Location	The fencing associated with Work No.5 will be located as shown in the area of Work No.5 on the Works Plans (Document Reference 2.2).
	Scale	The fencing will have a maximum height of 2m.
	Design	The fence is likely to be a deer fence . The fence would be designed in such a way to allow small animals to pass through.
	Design	The fence will be gated.
<b>Access tracks</b>	Location	The access tracks associated with Work No.5 will be located in the area of Work No.5 on the Works Plans (Document Reference 2.2).
	Location	Where possible, access tracks are to be located outside of the flood zones. Where tracks are located within the fluvial flood zone they will remain at grade to ensure there is no loss of flood plain.
	Location	The access tracks will be located towards lower quality land available (that in Subgrade 3b quality) wherever possible.
	Location	The access tracks will be located to pass through existing gates and gaps in hedgerows where feasible.
	Design	The access tracks will be permeable to allow water to filtrate through and maintain greenfield runoff rates.
	Design	Any small impermeable areas will have an apron of clean crushed stone to promote natural land drainage conditions in the vicinity of the structures. The apron will be at least 1m wide beyond the structure footprint with a depth of at least 300mm consisting of 40-70mm crushed stone.
<b>Drainage</b>	Location	The drainage associated with Work No.5 will be located in the area of Work No.5 on the Works Plans (Document Reference 2.2).

Element of Proposed Development	Parameter type	Design principle
	Design	Detailed operational drainage design will be undertaken prior to construction.
	Design	Sustainable drainage solutions (SuDS) will be provided at source, ensuring that surface water run-off is managed as per existing site conditions.
<p><b>Work No. 6 – Within the National Grid substation construction of electrical substation infrastructure including:</b></p> <ul style="list-style-type: none"> <li>(a) a compound for electrical works necessary for the onwards transmission of electricity containing, but not limited to, cable switchgear and electrical equipment including power transformers, reactive compensation equipment, filters, cooling equipment, control and welfare buildings, lightning rods, internal roads, security fencing, and other associated equipment, structures and buildings including noise-attenuation works;</li> <li>(b) electrical cables</li> <li>(c) 132 kilovolt connection bay located at the Norton 132 kilovolt GIS switch room including all associated electrical equipment and civil works necessary to enable the onward transmission of electricity;</li> <li>(d) access gates and tracks.</li> </ul>		
<p><b>Electrical works to connect and extend the existing National Grid substation</b></p>	Location	The works to the National Grid substation will be located as shown as Work No 6 on the Works Plans (Document Reference 2.2).
	Design	A new 132kV circuit breaker and associated switchgear equipment will be installed at the Norton Substation by the DNO as the asset owner of the substation.
<p><b>Work No. 7 – temporary construction and decommissioning of access tracks and compounds comprising:</b></p> <ul style="list-style-type: none"> <li>(a) works to improve existing farm access from public highway, and install temporary traffic lights, banksmen or other measures to manage traffic;</li> <li>(b) works to excavate and store soil, clear vegetation and obstacles, level, shape and prepare surface for construction track to be installed;</li> <li>(c) storage of equipment and materials including waste skips;</li> <li>(d) civils investigations and works to reinforce ground with weight-bearing support infrastructure, maintain integrity of structures beneath road surface;</li> <li>(e) creation of temporary construction access tracks, laydown and working areas;</li> <li>(f) works required for crossing, moving, re-routing or over/undergrounding of existing utility assets (including water, gas, sewer pipes, electricity distribution/transmission cabling, telecommunications etc.);</li> <li>(g) temporary stopping up of watercourses for installation of culverts, drainage and other features to cross water courses;</li> <li>(h) areas of hardstanding;</li> <li>(i) car parking;</li> <li>(j) site and welfare offices, canteens and workshops;</li> <li>(k) area for download and turning;</li> <li>(l) security infrastructure;</li> <li>(m) site drainage and waste management infrastructure; and</li> </ul>		



Element of Proposed Development	Parameter type	Design principle
(n) electricity, water, waste-water and telecommunications connections.		
<b>Temporary construction compounds</b>	Location	The temporary construction compounds will be located as shown as Work No. 7 on the Works Plans (Document Reference 2.2).
	Location	Compounds have been located towards lower quality land available (that in Subgrade 3b quality) wherever possible.
<b>Temporary access tracks</b>	Location	The temporary access tracks will be located as shown as Work No 7 on the Works Plans (Document Reference 2.2).
	Design	Areas of temporary tracks would be completed as soon as possible and surfaced appropriately to protect soils from runoff.
<b>Temporary fences</b>	Design	Temporary fences or markers will be used to ensure minimal disturbance of the surrounding land.
<p><b>Work No. 8 – works to facilitate access for all works, comprising:</b></p> <p>(a) creation of accesses from or across the public highway;</p> <p>(b) visibility splays;</p> <p>(c) works to widen and surface the public highway; and</p> <p>(d) installation of temporary traffic lights or facilities for manned traffic management.</p>		
<b>Works accesses</b>	Location	The access works will be located as shown as Work No 8 on the Works Plans (Document Reference 2.2).
	Location	Existing farm accesses have been used.
	Design	The access tracks will be permeable to allow water to filtrate through and maintain greenfield runoff rates.
	Design	Any small impermeable areas will have an apron of clean crushed stone to promote natural land drainage conditions in the vicinity of the structures. The apron will be at least 1m wide beyond the structure footprint with a depth of at least 300mm consisting of 40-70mm crushed stone.
<p><b>Work No. 9 – works for areas of green infrastructure comprising:</b></p> <p>(a) soft landscaping and planting, including tree and hedgerow planting;</p> <p>(b) habitat creation and management including earthworks, landscaping, means of enclosure and the laying and construction of drainage infrastructure; and</p> <p>(c) laying down of permissive paths, signage, and information boards.</p>		
<b>Soft landscaping and planting</b>	Location	Tree and hedgerow planting will be in accordance with the Environmental Masterplan (Document Reference 2.5).
	Location	Tree and hedgerow removal and protection will be in accordance with the Arboricultural Impact Assessment (Document Reference 6.4.7.7).

Element of Proposed Development	Parameter type	Design principle
<b>Habitat creation and management including earthworks, landscaping, means of enclosure and the laying and construction of drainage infrastructure.</b>	Location	The areas for mitigation, planting, enhancements and retained agriculture will be located as shown in Work No 9 on the Works Plans (Document Reference 2.2).
	Location	There will be an 8m buffer around all mapped watercourses that cross the Proposed Development.
	Design	Discrete biodiversity enhancement areas will be provided that will remain free of solar panels, as depicted in the Works Plans (Document Reference 2.2) and the Environmental Masterplans (Document Reference 2.5). Eight land parcels currently used for intensive agriculture across the Order Limits are to be used for biodiversity enhancement and will remain free of solar PV modules. These areas will provide enhanced foraging opportunities for birds and bats
	Layout	A buffer zone around Little Stainton Beck has been incorporated into the design to allow the watercourse to maintain natural course and allow space for geomorphic movements due to increase future flows
<b>Laying down of permissive paths, signage, and information boards</b>	Location	The routing of permissive paths will be as shown on the Street Works, Rights of Way and Access Plan (Document Reference 2.3).
<b>Parameters relevant to Order Limits</b>		
	Design	Sediment control measures (silt fences, settlement/attenuation ponds etc.) would be used in the vicinity of watercourses, springs or drains where natural features (e.g., hollows) do not provide adequate protection.
	Design	Permanent relocation or longer-term storage of soils would be re-instated with vegetation as soon as practicable.
	Design	No construction activities will take place within the watercourse buffer zones.
	Design	New watercourse crossings will be designed to ensure they do not disconnect the watercourses at times of low flow and will be designed with appropriate freeboard for flood flow capacity.
	Design	New watercourse crossings will be designed to ensure fish and mammal movement is not restricted, increased erosion will not occur and have a buried invert so the natural bed formation remains in situ.
	Design	The proposed tree stock will include a mix of bare root transplants (80-100cm, 1+2 transplants) together with standard and extra heavy standard woodland trees in locations where initial impact of the planting is required.

Element of Proposed Development	Parameter type	Design principle
	Design	The bare root tree stock will be planted at 2m centres with standard/extra heavy standard trees interspersed at 5m centres to create a varied canopy structure.
	Design	Tree pits should have a radius of at least 75mm greater than that of the root system.
	Design	The proposed tree stock will include standard and extra heavy standard trees in locations planted at between 10-20m centres along the hedgerow.
	Design	The proposed hedgerow species will be planted at 300mm centres in a double staggered row with five plants per linear metre.
	Design	Scrub stock will consist of bare root stock (80-100cm, 1+2 transplants) to be planted at 1.5m centres.
	Design	There will be 10 barn owl boxes installed on retained trees, in locations determined by an ecologist at the time of installation.
	Design	Approximately 50 bat boxes will be installed on retained trees.
	Design	Where possible, the design and layout seeks to retain woodland, hedgerows and trees. Trees and hedgerows of value to foraging bats are to be retained, with removal of hedgerow focused on poor quality hedgerow where possible.
	Design	Components of the Proposed Development required for the operation of the Proposed Development would be removed during decommissioning. Any requirements to leave certain infrastructure, for example the access tracks, would be discussed and agreed with landowners as part of the decommissioning process
	Design	No new proposed access tracks are within 100m radius of the location of the identified public water supplies (PWSs). Only solar PV panels are proposed within these zones.

## 8.4. Technology Advancements

- 8.4.1. Requirement 3 of the Draft DCO outlines that no phase of the authorised development may commence until details of the various aspects of the proposed development have been submitted to and approved in writing by the relevant planning authority.
- 8.4.2. In preparing this detailed design, the Applicant must accord with the location plan, works plans, environmental masterplan, principles and assessments set out in the ES and this Design Approach Document.

- 8.4.3. The authorised development must then be carried out in accordance with the approved details.
- 8.4.4. During examination of the Proposed Development the potential effect of improvements in technology between the point of application and the detailed design / construction of the Proposed Development was mentioned by the Examining Authority as well as various Interested Parties.
- 8.4.5. The Applicant acknowledges that the design assessed at the application stage (preliminary design) is done so at a point in time based on knowledge and understanding of the current technology available. In the time that will elapse between grant of DCO and finalisation of detailed design, there is potential for technological improvements (particularly in solar panel technology) that would enable amendments to the preliminary design, within the defined parameters secured under the DCO.
- 8.4.6. It is usually in the Applicant's interest to utilise the most advanced technology at the time of procurement / construction, however, there may also be reasons why a higher wattage panel may not be preferred (e.g. efficiency of the panels and output within the locational characteristics of the site).
- 8.4.7. The Applicant is therefore committed to review the Proposed Development at the detailed design stage specifically with reference to available solar panel technology. In a scenario where panel technology (considered in the round with factors such as overall efficiency, procurement and size etc.) means that the Applicant can potentially maximise the available grid connection capacity whilst utilising less land, the focus of any rationalisation would be on the following priority areas which have been discussed with Interested Parties representing the local communities (not currently presented in a priority order):
- East and South of Great Stainton
  - North and East of Bishopton
  - Increased setbacks from boundaries in Panel Areas B, C and E
- 8.4.8. It has been agreed with the communities that focussing any reductions in panel areas in the above locations would have the biggest overall positive impact and therefore no other areas beyond those listed will be considered.
- 8.4.9. This commitment is based on consideration of a potential change in technology that is not known at the time of consent. If there is improved technology that can contribute to a reduced panel area, when also considering other factors such as efficiency, technical design, supply chain, procurement and overall generating capacity and grid connection capacity, that will be taken account of in the eventual detailed design submitted by the Applicant under Requirement 3. This does not include any other design parameters as consented by the Secretary of State, such as interrow spacing. There remains a scenario whereby the RWE design team choose to use technology (taking account of those factors outlined above) that doesn't allow for a reduction in

the overall scheme and should this be the case, this would be communicated to the LPA as part of the Requirement submission.

- 8.4.10. The Applicant is committed to undertaking this review and reporting the outcomes of the review to the LPA as part of the detailed design submission. It is not until this point in time that the extent of any changes would be fully known.



## 9. Conclusion

- 9.1.1. This Design Approach Document seeks to provide a rationale and explanation for the Applicant's design journey for the Proposed Development, including how it has taken into account and considered the surrounding landscape and site context, and the requirements for 'good design' as enshrined in the relevant National Policy Statements.
- 9.1.2. By necessity, elements of the Proposed Development have been designed in such a way to ensure that safety and viability are at the forefront. However, the Applicant has committed to developing a design which not only provides a safe and reliable source of renewable energy generation, but one that is in keeping with the local landscape and ensures that local communities and visitors alike can continue to access and enjoy the natural landscape and environment around them.
- 9.1.3. The delivery of the Proposed Development would align with legislation, policy and strategy priorities relating to decarbonisation, energy security, and energy affordability. In doing so, it establishes the evidenced need for the principle of the Proposed Development which is fully established within the Planning Statement (Document Reference 7.1).
- 9.1.4. The Proposed Development would have the capacity to generate over 50MW of electricity, responding to the urgent need for new renewable energy infrastructure that is established through:
- national legislative commitments;
  - national policy;
  - local planning policy and climate emergency declarations;
  - national energy strategy; and
  - energy market demand and security concerns.
- 9.1.5. Alongside an established needs case, Byers Gill Solar would provide a series of wider benefits, both locally and nationally, as identified within the Planning Statement (Document Reference 7.1).
- 9.1.6. Mitigation and enhancement have been at the heart of the design process for the Proposed Development, by placing embedded mitigation at the forefront. This means that rather than simply providing mitigation for the effects arising from the proposals, the Applicant has ensured that their design has sought to reduce effects upfront where practicable and possible to do so and include the measures as part of the Applicant's standard design.